

## Description and operating instructions

Pag. 15. 3



## TOUCHDEX indexing tables

Pag. 15. 8

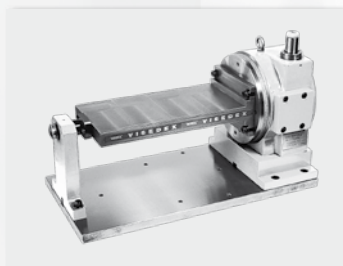

## COMBIDEX

Pag. 15. 14



## TILTING

Pag. 15. 15



## Accessories

Pag. 15. 16

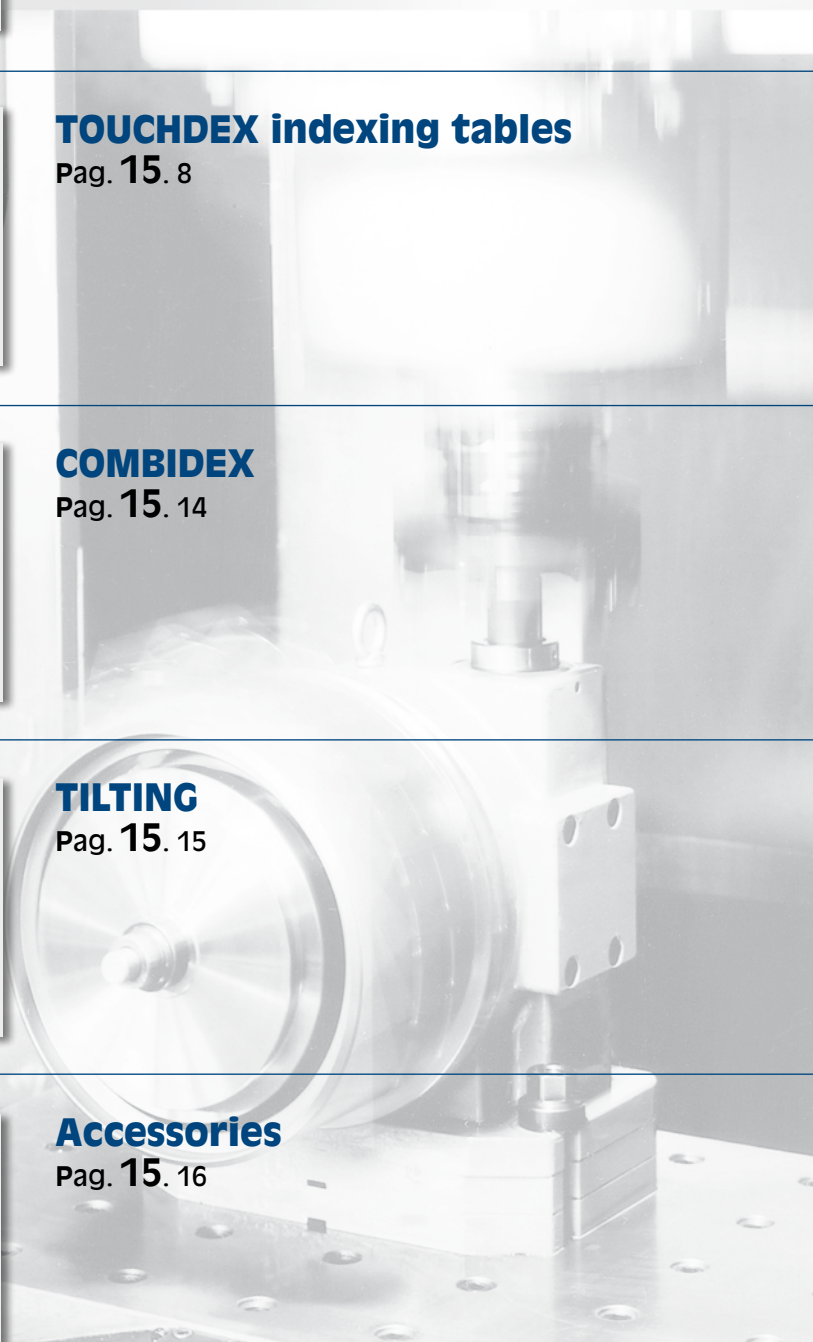

On our website: [www.omlspa.it](http://www.omlspa.it)  
(in the video section) are available some videos by means  
of which we show how TOUCHDEX works.

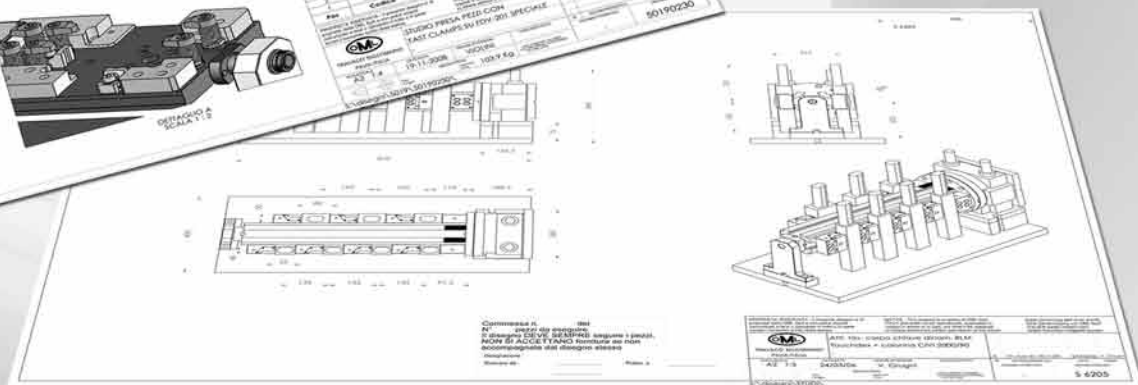
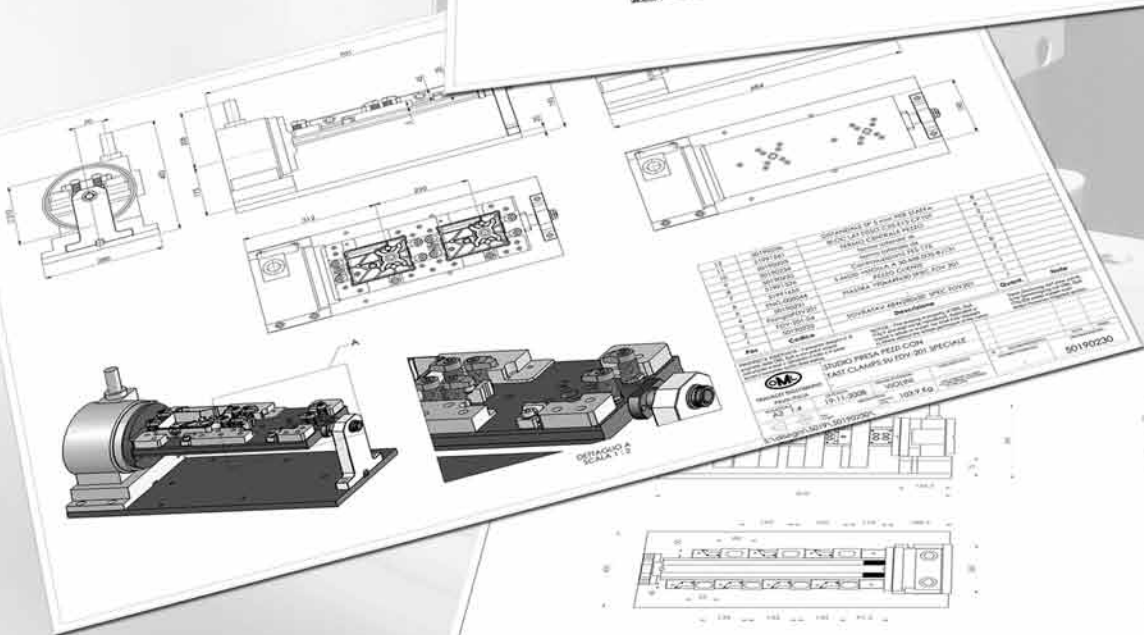
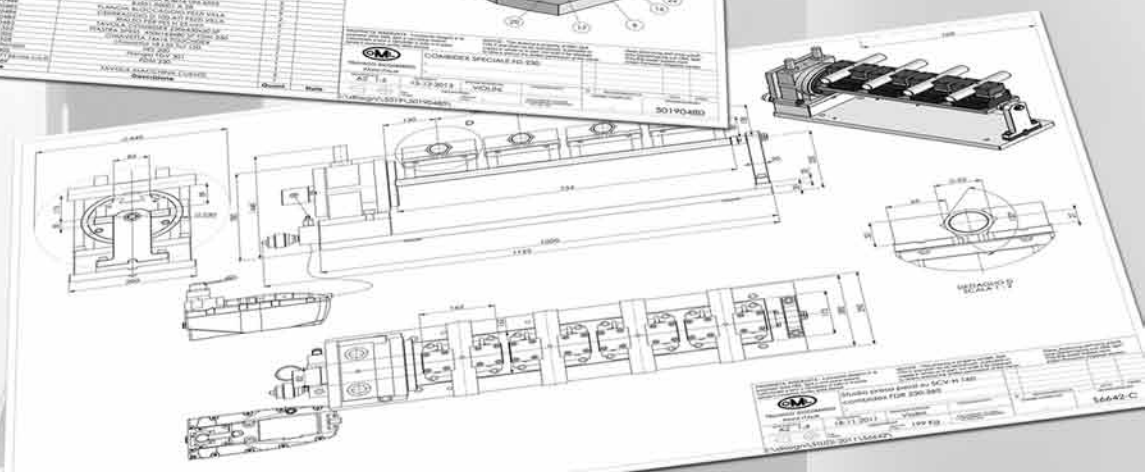
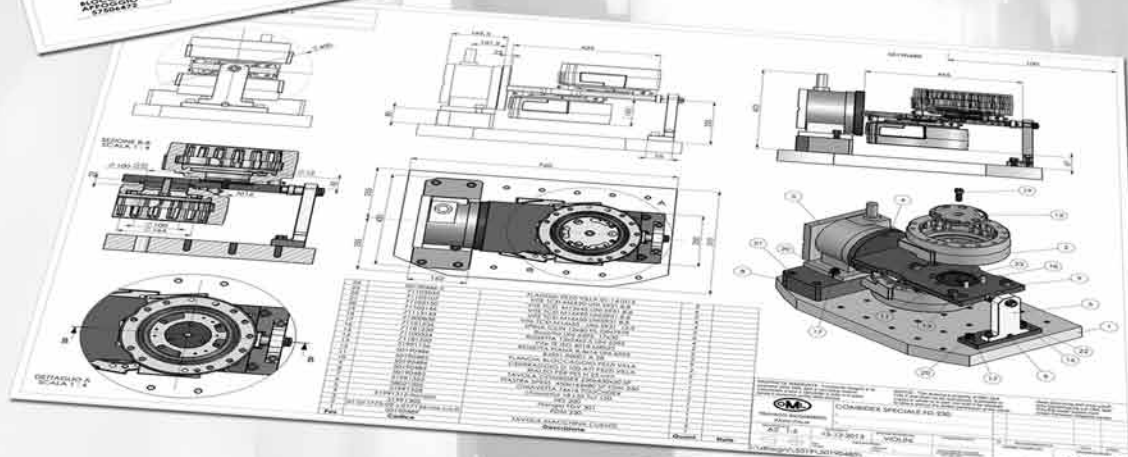
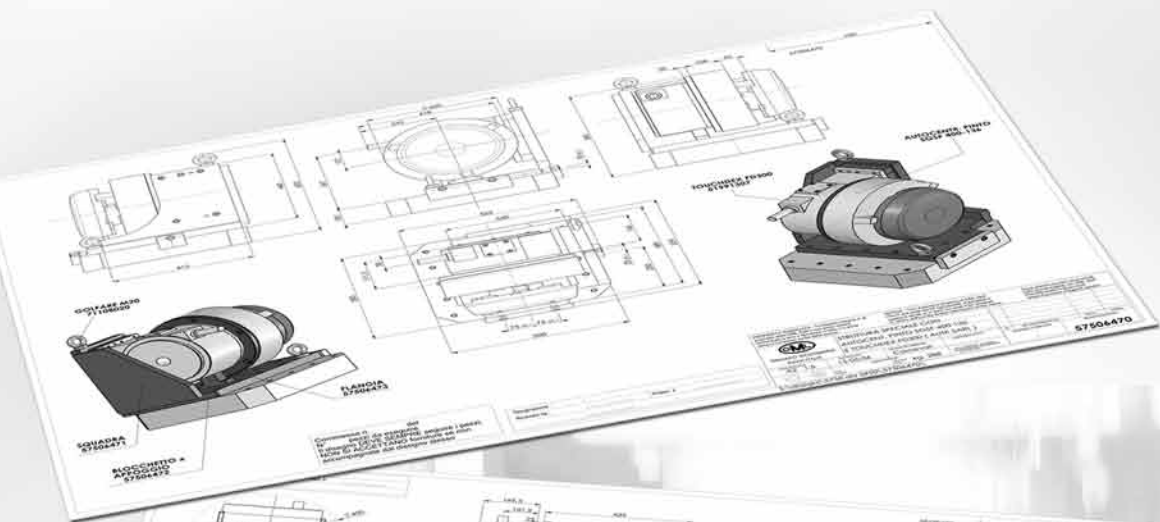

## HIGH RIGIDITY AND PRECISION OF THE SYSTEM

TOUCHDEX



Exclusive Mechanical clamping System “LOCKING PIN”

CNC System

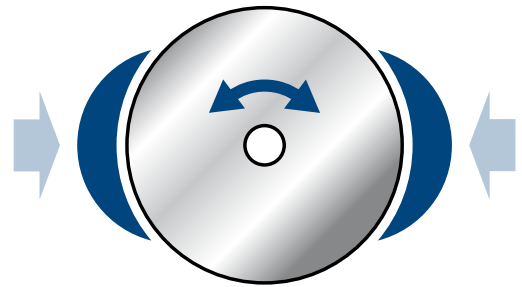

Traditional braking jaws system

The exclusive TOUCHDEX system provides a clamping force 2 to 3 times that an ordinary index table thus allowing heavy machining.

Example	Face Milling	Drilling	Drilling
Machining S45C Material			
FD-200	Δ 80 Face mill 3 mm (depth of cut) 130 mm/min (Feedrate)	Δ 35 Drill 20 mm/min (Feedrate)	Δ 20 Drill 30 mm/min (Feedrate) H = 80 mm
FD-300	Δ 80 Face mill 3 mm (depth of cut) 130 mm/min (Feedrate)	Δ 40 Drill 20 mm/min (Feedrate)	Δ 25 Drill 30 mm/min (Feedrate) H = 90 mm

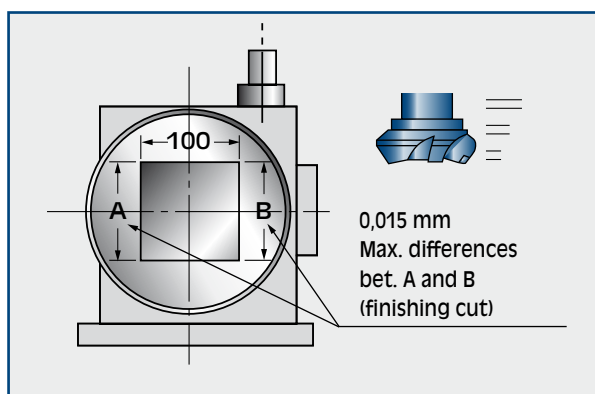

## HIGH PRECISION

- Indexing accuracy of less than 30"
- Repeat accuracy ± 3"

The unique clamping system ensures high accuracy despite locking pin wear, and with 0 backlash for the life of the unit (see example)

### VERSATILITY OF THE SYSTEM

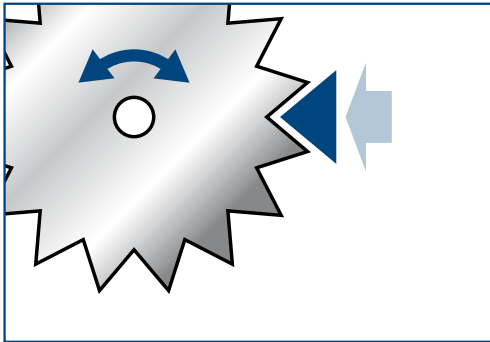

- **Minimum space required**

Since it has no motorized part, it can be installed in a minimum amount of space

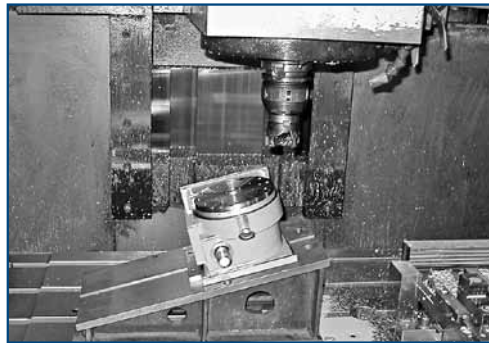

- **Versatility**

Since it has no electric or pneumatic connections, it can be installed on MULTI-PALLET machining centers either vertical or horizontal with the possibility to create flexible production systems

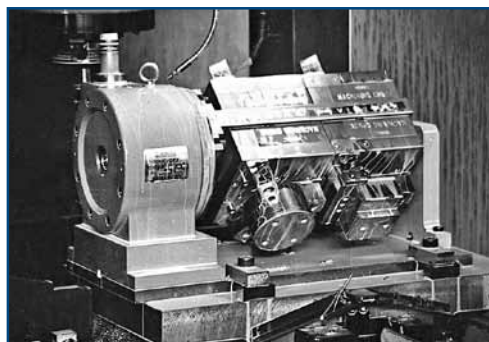
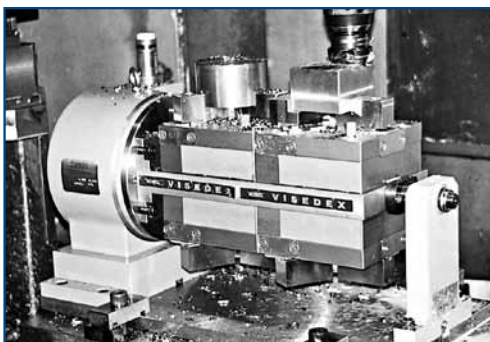
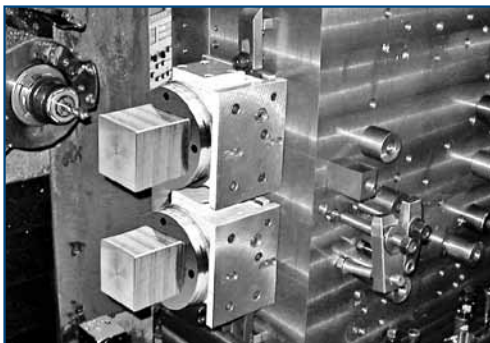

- **Easily mounted**

As a power control cable is not required the displacement from a machining center to another one is very easy

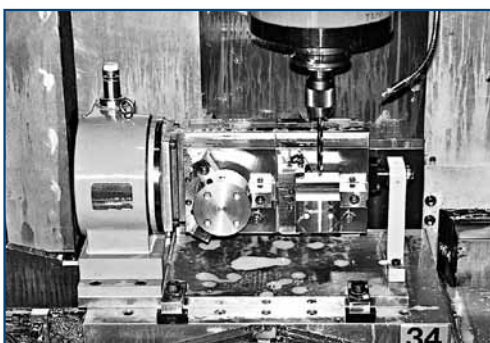

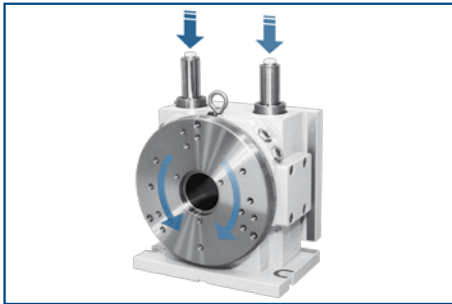
**VARIETY OF TOUCHDEX MODELS AVAILABLE****FDR**

Indexing and rotation in TWO directions

- Left pushbar for counterclockwise
- Right pushbar for clockwise

**FDM**

With the adaption for the installation either in horizontal or in vertical

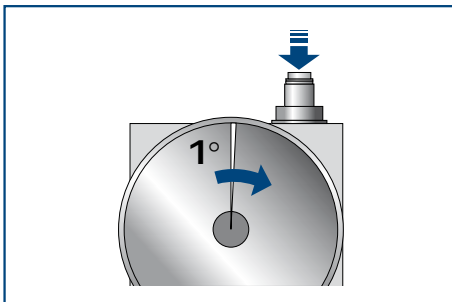
**FD - ... - 360**

1 deg. Indexing ideal for workpieces of complex shape

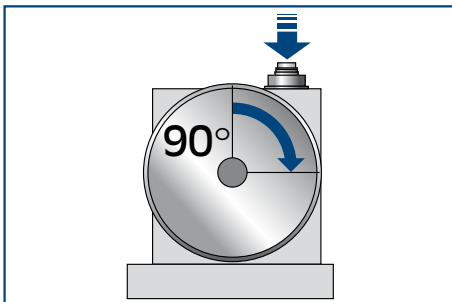
**FD - ... - 04**

90 deg. Indexing rotation per stroke. Pressing the pushbar down one rotate the table by 90 deg. Ideal for square workpieces

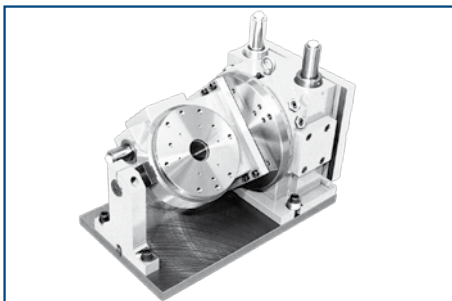
**TILTING 230-150**

Five-face machining. Integrates FDR-230 and FDM-150 for five-face machining on vertical machining centers

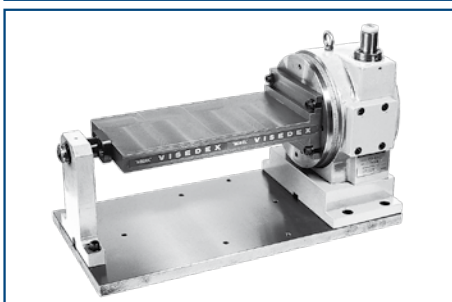
**COMBIDEX**

Integrates subplate and plate for workholding applications

### WORKING

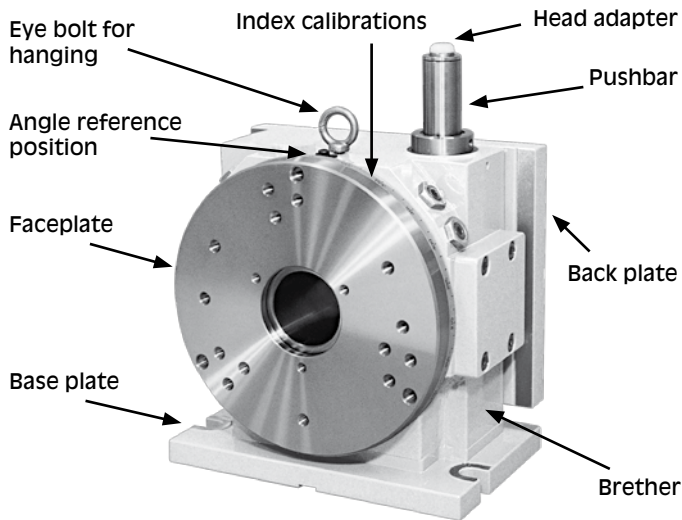

### INTERNAL MECHANISM

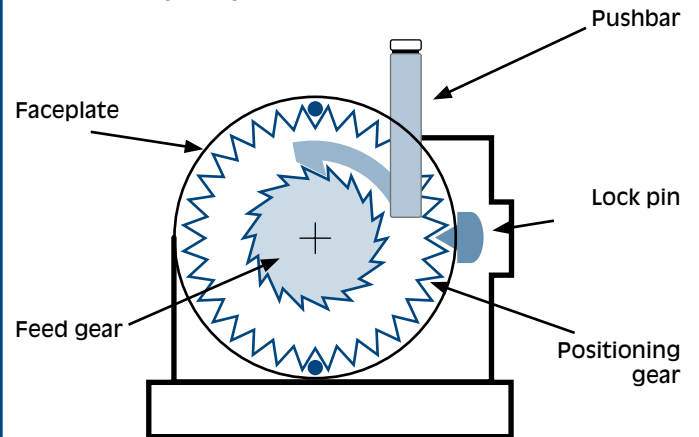

- 1** When the pushbar is pressed down a little, the lock pin retracts due to a grooved cam mechanism.

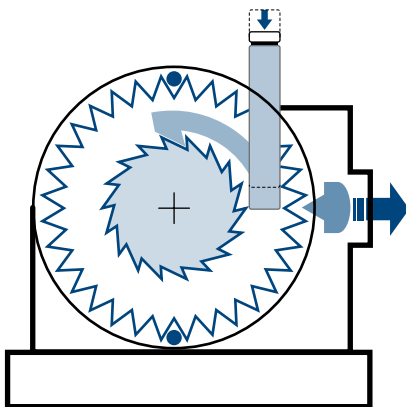

- 2** When pressed down further, the faceplate begins to rotate.

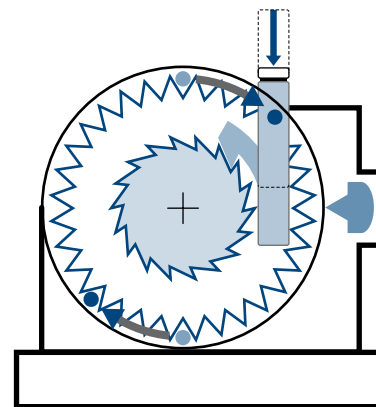

- 3** The pushbar returns, but until a certain position is reached the faceplate and the lock pin continue to be as they were.

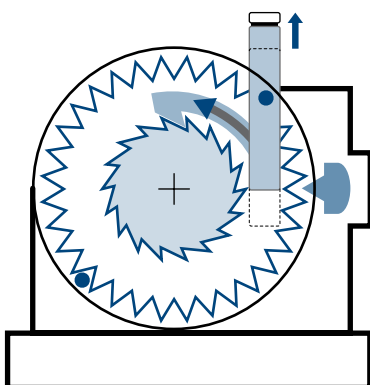

- 4** When the pushbar reaches the top most position, the lock pin engages with the positioning gear and fixes the table.

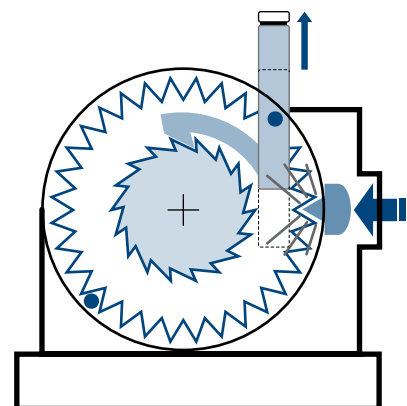

## PROGRAMMING

**\* POSITION A** Using handle mode.

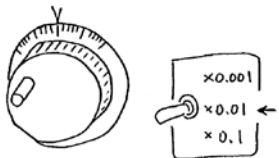

Do not rotate the tool!

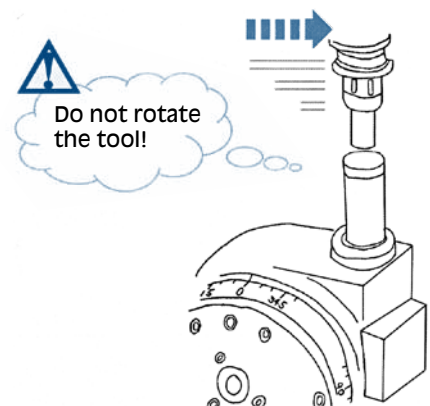

Move the tool over the pushbar, using manual mode.

Read and memory Z axis number.

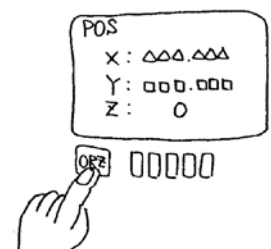

**\* POSITION B** Using handle mode.

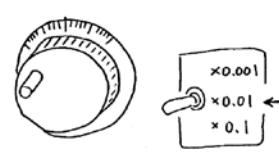

Adjust the indexing as accurately as your eyes can master.

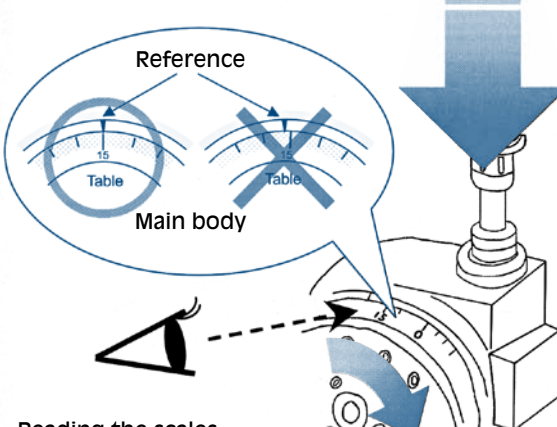

Reading the scales on the side of the table, move the Z axis with manual handle mode until the indexing is completed.

Read and memory Z axis number.

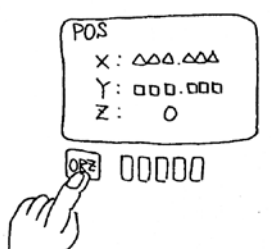

**PROGRAM**

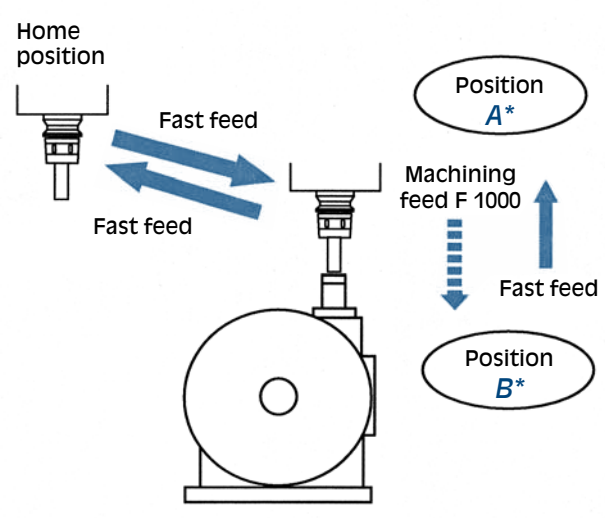

**INFORMATION**

**Regarding the push-in tool**

Providing the drill is  $\varnothing$  10 mm or wider and no bending is caused during the pushing down, the tool you are using is appropriate.

If a tool with a sharp tip is used, it will badly wear down the resin and the resin will have to be replaced.

The main shaft cover can also be used to push down.

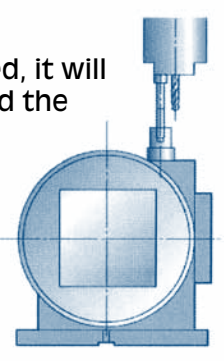

Code	Type	Indexing angles		Pushbar Stroke mm
		Min°	Max °	
<b>51 99 13 20</b>	<b>FDK-450</b>	<b>5°</b>	<b>45°</b>	<b>93</b>

## FDK-450



**New**

## LARGEST TOUCHDEX Table Dia 450mm

Large Center Hole Secured



Center Hole:  $\varnothing$  120mm

### Standard equipment with a Brake Ring Function

Brake Ring Function. This function suppresses a decrease in clamping force during indexing by continuously applying a constant friction force to the table. This function can respond to more unbalanced workpieces / jigs

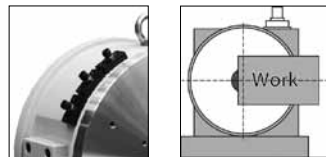

### A manual indexing unit (MH-6) is supplied as standard accessory

With a lock cancelation function

Manual Unit MH-6  
(stroke: 15mm)

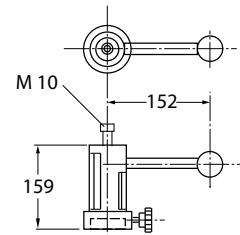

Type	FDK-450	
Table Diameter	mm	450
Center Heigh	mm	250
Spindle Bore Diameter	mm	120
Table indexing angles at full pushbar stroke	deg.	45
Min. indexing angles	deg.	5
Approx. Full pushbar stroke	mm	93
Approx. pushbar load	N (kgf)	1960 [200]
Loadings	kg	450
Allowable Unbalanced weight (differences in load at table periphery)	kg	40
Allowable load (Table clamped)	N-m (kgf-m)	4560 [465]
Accuracy	sec	30
Repeatability	sec	$\pm$ 3
Weight	kg	214

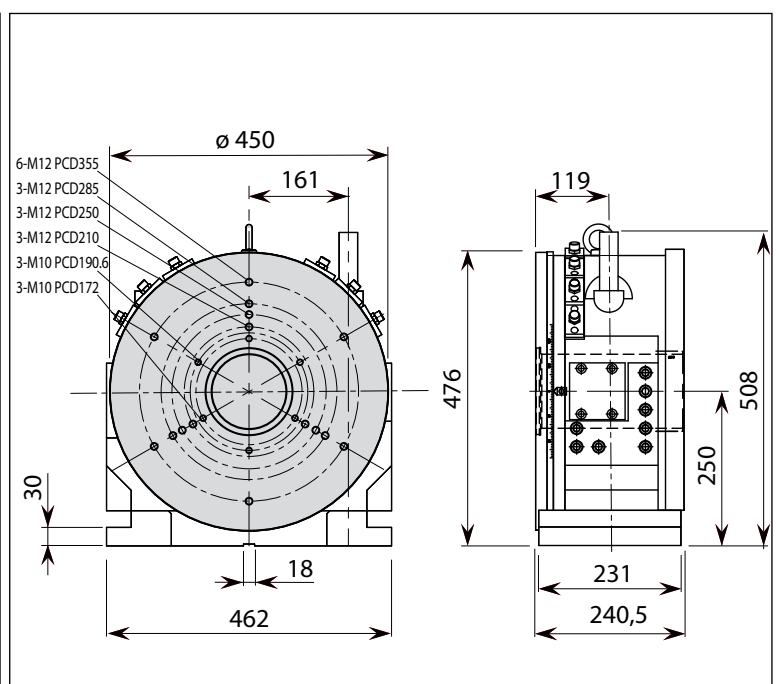



Code	Type	Indexing angles		Pushbar Stroke mm
		Min°	Max °	
<b>51 99 13 59</b>	<b>FD-107</b>	<b>15°</b>	<b>45°</b>	<b>24</b>

# FD-107



New

## SMALLEST TOUCHDEX Table Dia 107mm

- Light-weight Compact
- Weight: 13kg
- Table indexing angles at full pushbar stroke: 45 deg.
- Min. indexing angles: 15 deg.

The detachable base plate diversifies mounting ways

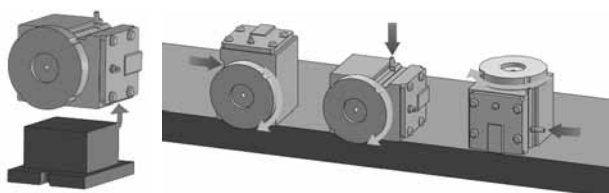

Example of installation

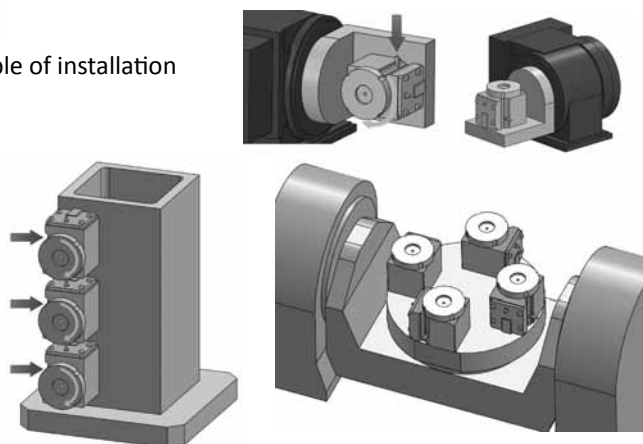



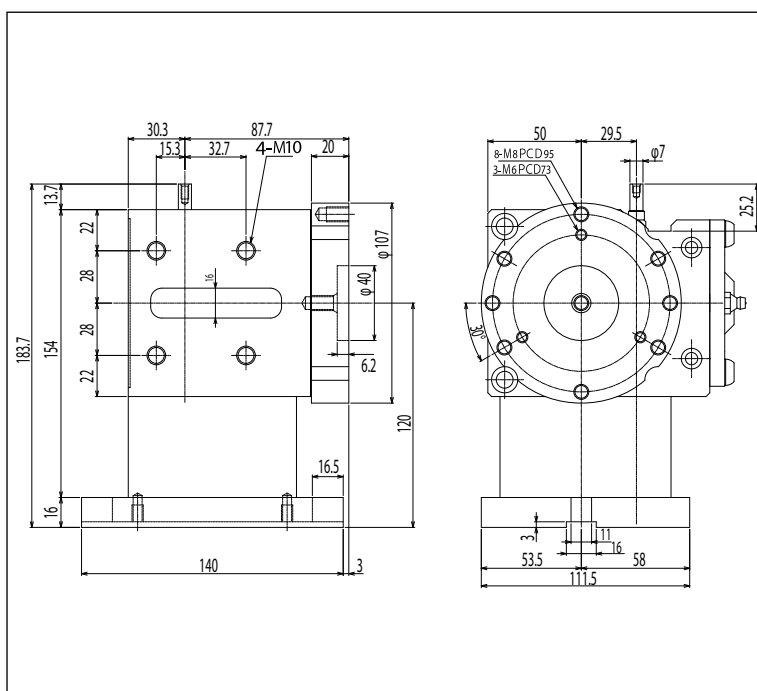

Type		FD-107
Table Diameter	mm	107
Center Heigh	mm	120
Spindle Bore Diameter	mm	-
Table indexing angles at full pushbar stroke	deg.	45
Min. indexing angles	deg.	15
Approx. Full pushbar stroke	mm	24
Approx. pushbar load	N [kgf]	295 [30]
Loadings	kg	20
Allowable Unbalanced weight (differences in load at table periphery)	kg	4
Allowable load (Table clamped)	N-m [kgf-m]	196 [20]
Accuracy	sec	60
Repeatability	sec	± 3
Weight	kg	13

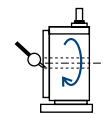

# “TOUCHDEX”

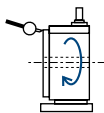
## TOLERANCES

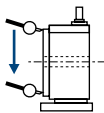
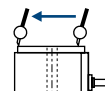
Inspecting item	Tollerances	Measurement Method (FD)	Measurement Method (FDM)
Table Center Hole Run-out	0.01 mm		
Table Surface Run-out (15 mm inside table periphery)	0.01 mm		
Table Surface Squareness (15 mm inside table periphery)	0.03 mm		

## SPECIFICATIONS

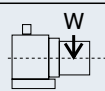
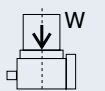
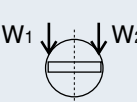
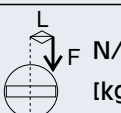
Type		FDM-150	FDMK-150-04	FD-200-04
Table diameter	mm	170	170	210
Spindle bore diameter	mm	37	37	16.5
Center height	mm	120	120	135
Table indexing angles at full pushbar stroke	gradi	45	90	90
Min. indexing angles	gradi	5	5	5
Full pushbar stroke	mm	38	53	78
Approx. pushbar load	N [kgf]	295 [30]	392 [40]	784 [80]
Loadings	vertical use  kg	200	200	250
	horizontal use  kg	300	300	---
Allowable unbalanced weight differences in load at table periphery	$W_1 - W_2$  kg	4	20	4
Allowable load (Table clamped)	$F \times L$  N/m [kgf/m]	588 [60]	588 [60]	1030 [105]
Accuracy	sec	30	30	30
Ripeatability	sec	±3	±3	±3
Weight	kg	30	37	38

Code	Type	Indexing Angles		Pushbar Stroke mm	A mm
		Min °	Max °		
<b>51 99 13 01</b>	<b>FDM-150</b>	<b>5°</b>	<b>45°</b>	<b>38</b>	<b>127</b>

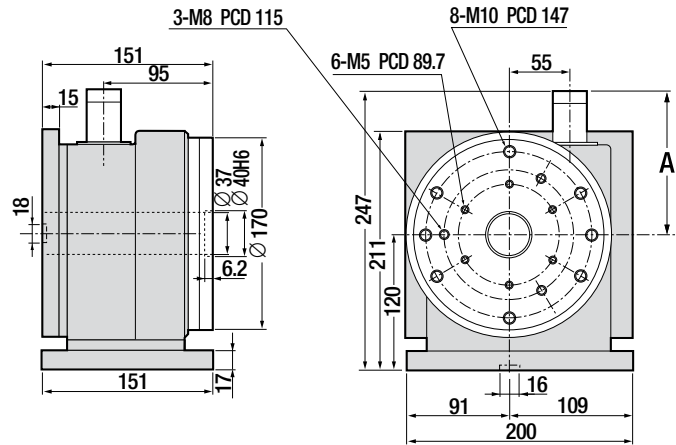

Code	Type	Indexing Angles		Pushbar Stroke mm	A mm
		Min °	Max °		
<b>51 99 13 16</b>	<b>FDMK-150-04</b>	<b>5°</b>	<b>90°</b>	<b>53</b>	<b>163</b>

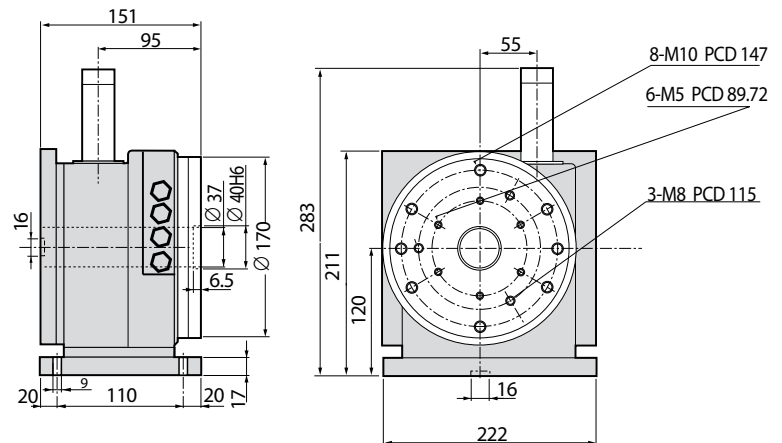
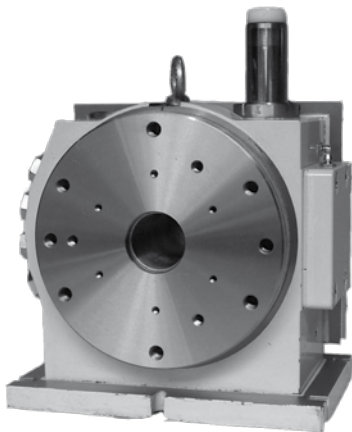



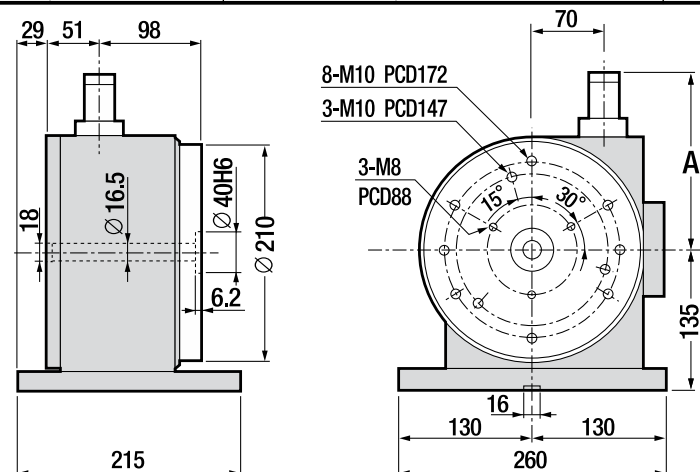



Code	Type	Indexing Angles		Pushbar Stroke mm	A mm
		Min °	Max °		
<b>51 99 13 02</b>	<b>FD-200-04</b>	<b>5°</b>	<b>90°</b>	<b>78</b>	<b>208</b>

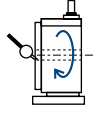

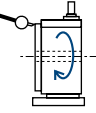

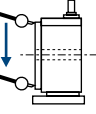
# “TOUCHDEX”

## TOLERANCES

Inspecting item	Tollerances	Measurement Method (FD)	Measurement Method (FDM)
Table Center Hole Run-out	0.01 mm		
Table Surface Run-out (15 mm inside table periphery)	0.01 mm		
Table Surface Squareness (15 mm inside table periphery)	0.03 mm		

## SPECIFICATIONS

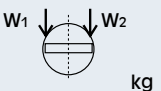
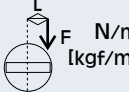
Type		FDM-230	FDM 230-360	FDR-230	FDR 230-360	FD-300	FD 300-360	FDMK 340	FDMK 340-360
Table Diameter	mm	230	230	230	230	310	310	340	340
Spindle Bore Diameter	mm	58	58	58	58	52	52	100	100
Center Height	mm	145	145	145	145	185	185	200	200
Table Indexing Angles at Full Pushbar Stroke	deg.	45	45	45	45	45	45	45	45
Min. Indexing Angles	deg.	5	1	5	1	5	1	5	1
Full Pushbar Stroke	mm	56	56	56	56	75	75	83	83
Approx. Pushbar Load	N [kgf]	784 [80]	784 [80]	1470 [150]	1470 [150]	1078 [110]	1078 [110]	1764 [180]	1764 [180]
Loadings	Vertical use  kg	250	250	250	250	350	350	350	350
	Horizontal use  kg	350	350	350	350	500	500	500	500
Allowable Unbalanced weight (differences in load at table periphery)	W <sub>1</sub> - W <sub>2</sub>  kg	4	4	20	20	4	4	20	20
Allowable load (Table clamped)	F x L  N/m [kgf/m]	1127 [115]	1127 [115]	1127 [115]	1127 [115]	2280 [232.5]	2280 [232.5]	2280 [233]	2280 [233]
Accuracy	sec	30	30	30	30	30	30	30	30
Repeatability	sec	±3	±3	±3	±3	±3	±3	±3	±3
Weight	kg	42	42	48	48	80	80	98	98

Code	Model	Indexing Angles		Pushbar Stroke mm	A mm
		Min	Max		
51 99 13 04	FDM-230	5°	45°	56	198
51 99 13 05	FDM-230-360	1°	45°	56	198

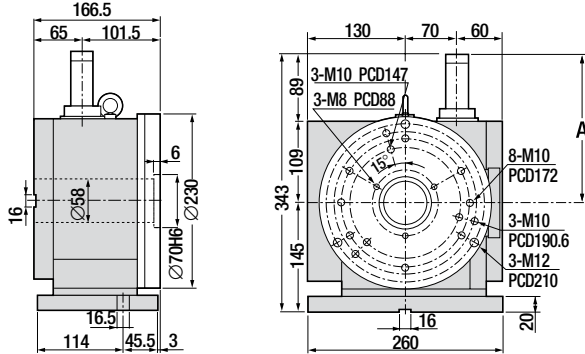
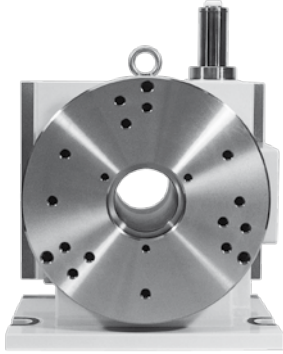

Code	Model	Indexing Angles		Pushbar Stroke mm	A mm
		Min	Max		
51 99 13 06	FDR-230	5°	45°	56	198
51 99 13 60	FDR-230-360	1°	45°	56	198

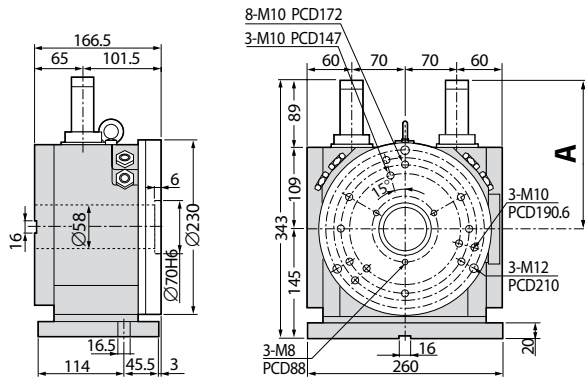
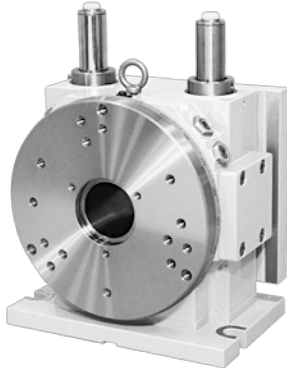

Code	Model	Indexing Angles		Pushbar Stroke mm	A mm
		Min	Max		
51 99 13 07	FD-300	5°	45°	75	233
51 99 13 08	FD-300-360	1°	45°	75	233

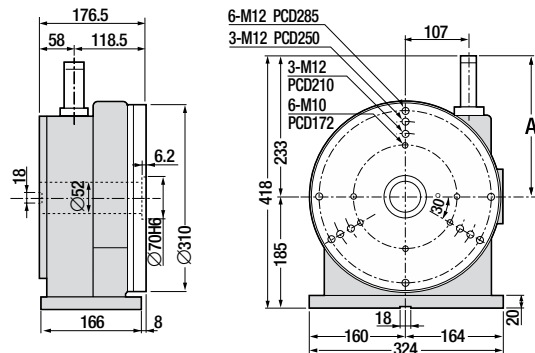
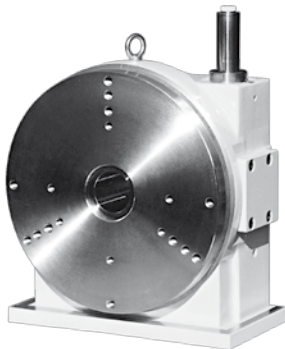

Code	Model	Indexing Angles		Pushbar Stroke mm	A mm
		Min	Max		
51 99 13 18	FDMK-340	5°	45°	83	240,5
51 99 13 19	FDMK-340-360	1°	45°	83	240,5

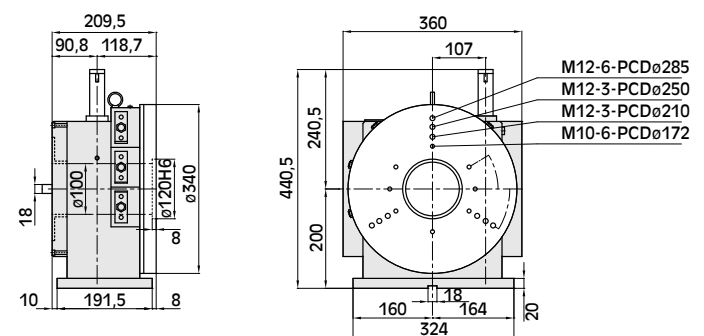
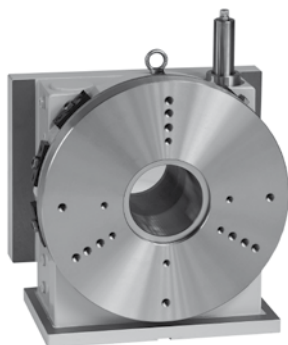

Code	Model	Indexing Angles		Pushbar Stroke mm	A mm
		Min	Max		
<b>51 99 13 11</b>	<b>FDV-201-04</b>	<b>5°</b>	<b>90°</b>	<b>78</b>	<b>208</b>

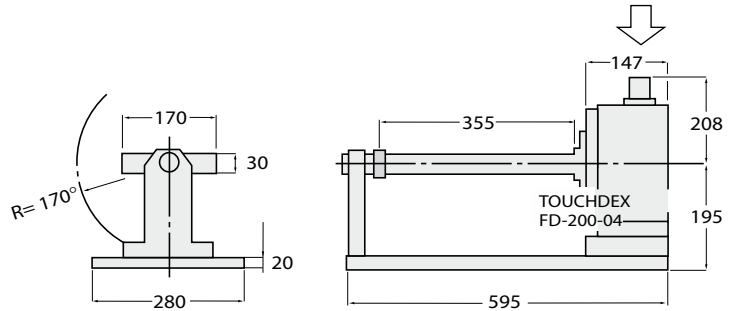
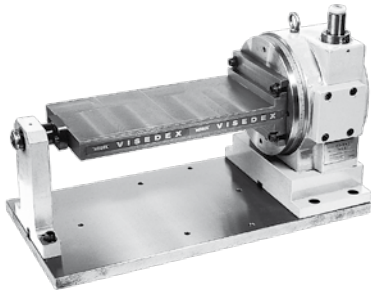

Code	Model	Indexing Angles		Pushbar Stroke mm	A mm
		Min	Max		
<b>51 99 13 12</b>	<b>FDV-301</b>	<b>5°</b>	<b>45°</b>	<b>75</b>	<b>233</b>

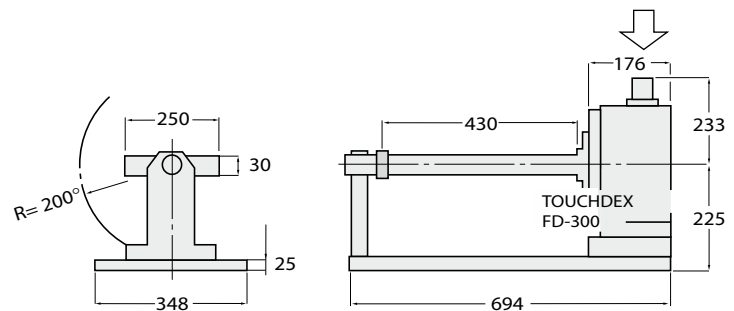
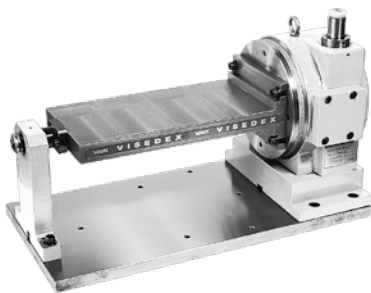

### Examples

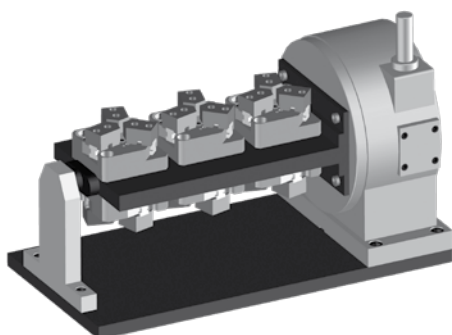

With SC square chuck

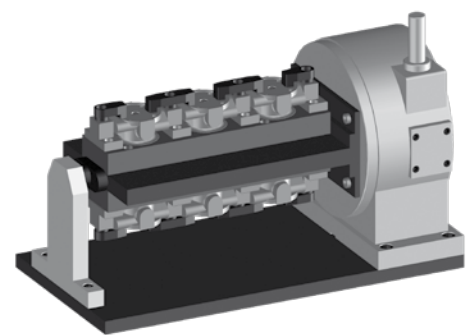

With clamping devices

With TC-t clamping system

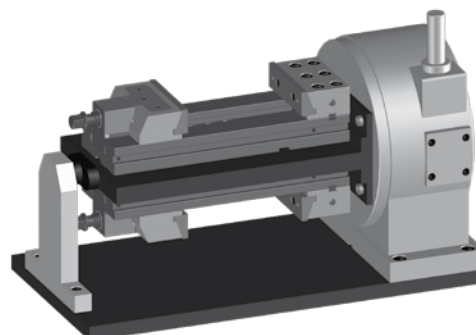

Code	type
<b>51 99 13 13</b>	<b>TL 230-150</b>

Code	type
<b>51 99 13 14</b>	<b>TL 340-230</b>

**Integrates FDR-230 and FDM-150 + FDR-340 and FDM-230 for five-face machining on vertical machining centers.**

- Table inclination and rotation adjusted automatically with the pushbar of TOUCHDEX.
- Minimum indexing angle in both inclination and rotation of 5°.
- Extremely compact footprint - 450 x 260 mm.

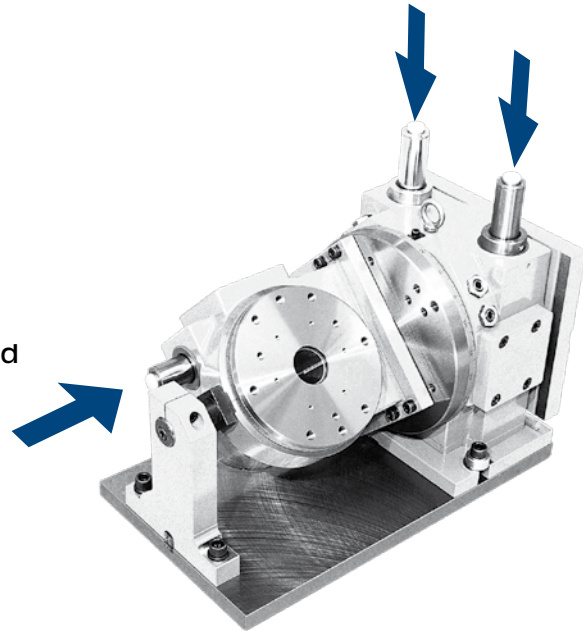

Specifications		TL 230-150	TL 340-230
Table Diameter	mm	170	230
Spindle Bore Diameter	mm	37	58
Center Height (90° Tilted)	mm	145	200
Table surface height (0 deg. tilted)	mm	200	265
Full Pushbar Stroke (Tilting)	mm	56	83
Full Pushbar Stroke (Rotation)	mm	38	56
Approx. Pushbar Load (Tilting)	N [kgf]	1470 [150]	1764 [180]
Approx. Pushbar Load (Rotation)	N [kgf]	295 [30]	1470 [150]
Loadings (0° to 90°)	kg	70	100
Allowable load (Table clamped)	FxL N-m [kgf·m]	1127 [115]	1960 [200]
	FxL N-m [kgf·m]	625 [63.8]	1.127 [115]
Accuracy (Tilting)	sec	30	30
Accuracy (Rotation)	sec	30	30
Repeatability (Tilting)	sec	±3	±3
Repeatability (Rotation)	sec	±3	±3
Weight	kg	98	215

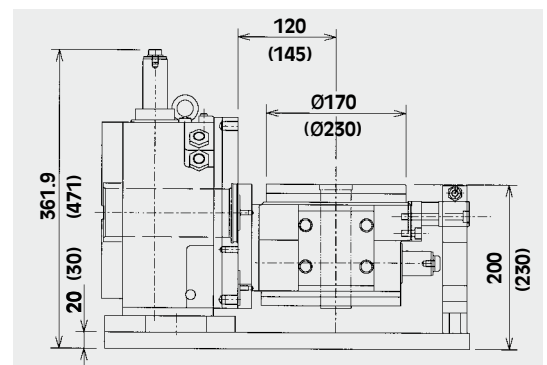
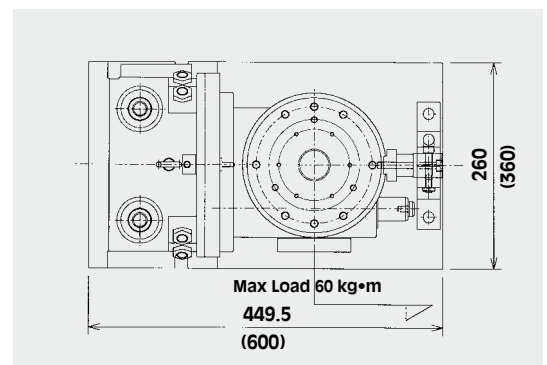
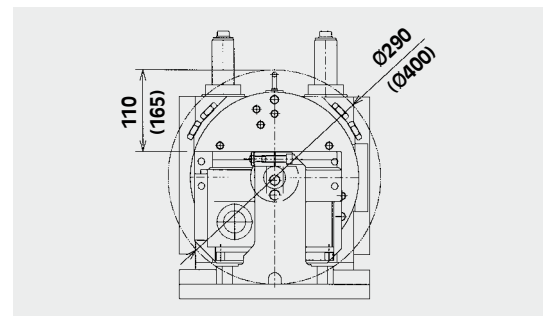

\* A counterweight may be required for balance when machining bar-shaped workpieces etc mounted significantly off-center on the TOUCHDEX.

## TAIL STOCK TK3

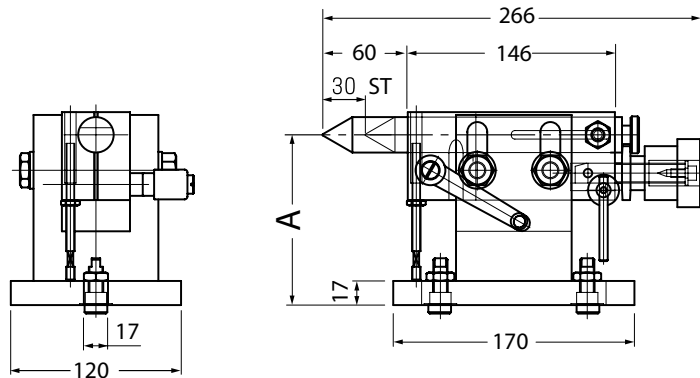
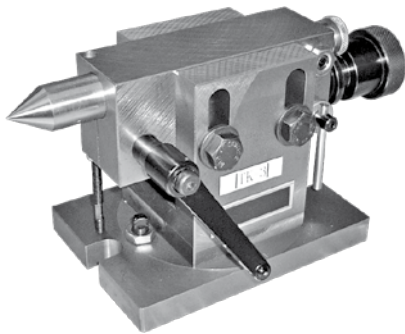

Code	type	A (mm)
51 99 13 21	TK-3	120 - 145
51 99 13 22	TK-3 HI	160 - 185

## END SUPPORT

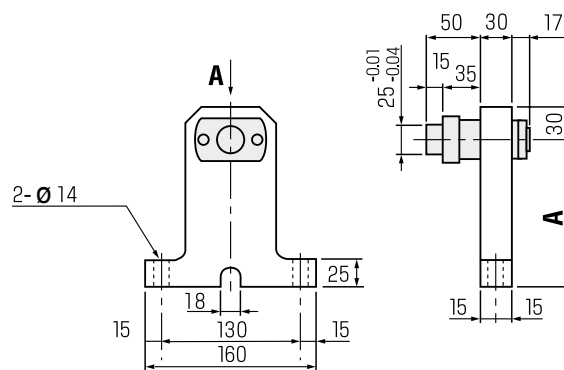
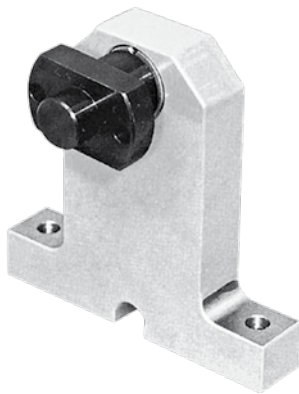

Code	type	A (mm)
51 99 13 23	FES-120	120
51 99 13 24	FES-135	135
51 99 13 25	FES-145	145
51 99 13 26	FES-175	175
51 99 13 27	FES-185	185
51 99 13 28	FES-200	200

## MANUAL HANDLE

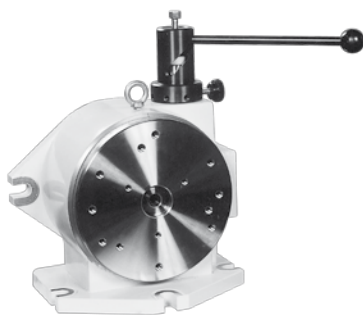

MH-2

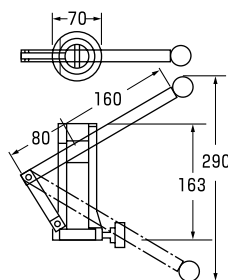

MH-3

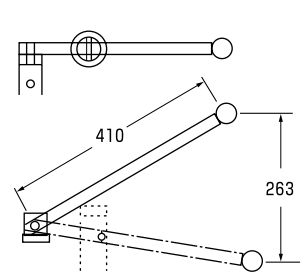

MH-1

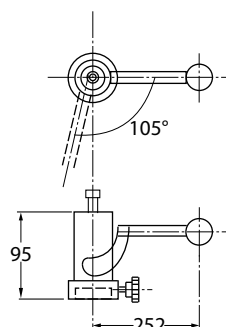

MH-5

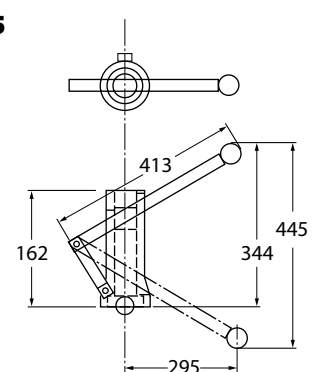

Code	type	stroke
51 99 13 30	MH-1	35
51 99 13 31	MH-2	88
51 99 13 32	MH-3	38
51 99 13 48	MH-5	95



Type	Tailstok	Manual handle	End support
<b>FDM-150</b>	<b>TK-3</b>	<b>MH-3</b>	<b>FES-120</b>
<b>FDR-150-04 (MK)</b>	<b>TK-3</b>	<b>MH-2</b>	<b>FES-120</b>
<b>FD (M)-200 (-360)</b>	<b>TK-3</b>	<b>MH-1</b>	<b>FES-135</b>
<b>FD (M)-200-04</b>	<b>TK-3</b>	<b>MH-2</b>	<b>FES-135</b>
<b>FD (M,R)-230 (-360) (MK)</b>	<b>TK-3</b>	<b>MH-2</b>	<b>FES-145</b>
<b>FDR-230-04 (-360) (MK)</b>	<b>TK-3-HI</b>	<b>MH-2</b>	<b>FES-175</b>
<b>FDM-300</b>	<b>TK-3-HI</b>	<b>MH-2</b>	<b>FES-185</b>
<b>FDMK-340 (-360)</b>	-----	<b>MH-5</b>	<b>FES-200</b>
<b>FDK-450</b>	-----	<b>MH-6</b>	-----

## K67



Code		
<b>10 73 12 23</b>	<b>Cartridge 500 g</b>	<b>Grease K67</b>
<b>10 73 12 24</b>	<b>Can 1000 g</b>	<b>Grease K67</b>

## GREASING KIT

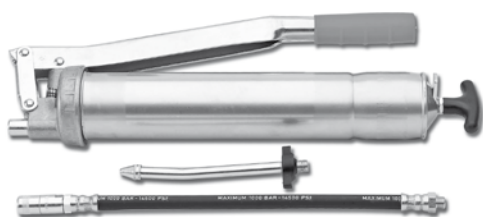

Code
<b>08 37 26</b>

## MOUNTING FLANGE FOR MANUAL CHUCK

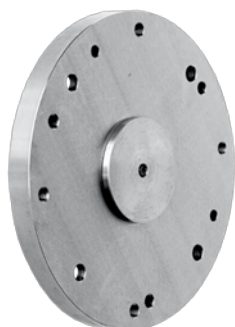

Codice	for type	for chuck	D (mm)
<b>51 99 13 41</b>	<b>FDM-150</b>	<b>SGSF 160-42</b>	<b>170</b>
<b>51 99 13 42</b>	<b>FD-200-04 / FD-200-360 FDM-230 / FDM-230-360 / FDR-230</b>	<b>SGSF 200-55</b>	<b>210</b>
<b>51 99 13 43</b>	<b>FD-300 / FD-300-360 FDMK-340 / FDMK-340-360</b>	<b>SGSF 315-103</b>	<b>310</b>
<b>51 99 13 47</b>	<b>FDK-450</b>	<b>SGSF 400-136</b>	<b>450</b>

## PAIR OF KEYS



Code	mm
<b>51 99 13 51</b>	<b>16 x 14</b>
<b>51 99 13 52</b>	<b>16 x 16</b>
<b>51 99 13 53</b>	<b>16 x 18</b>
<b>51 99 13 54</b>	<b>18 x 14</b>
<b>51 99 13 55</b>	<b>18 x 16</b>
<b>51 99 13 56</b>	<b>18 x 18</b>

### SGSF MANUAL CHUCK (frontal mounting) SMW self-centering manual chuck, steel body

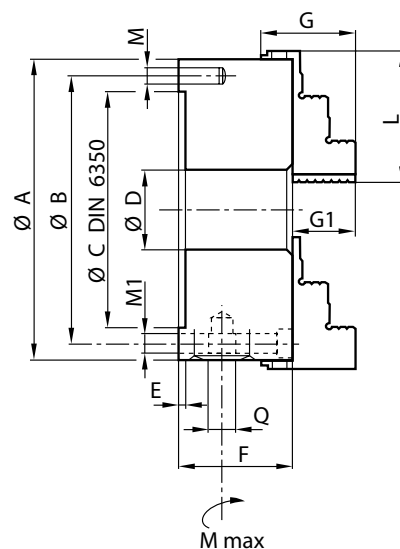
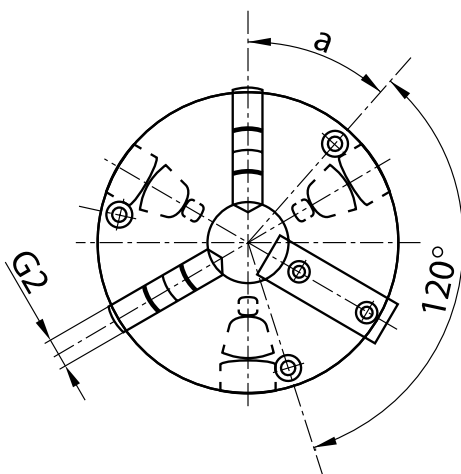

Code		33 03 12 16	33 03 12 20	33 03 12 31	33 03 12 40
Chuck		SGSF 160-42	SGSF 200-55	SGSF 315-103	SGSF 400-136
<b>Attachement DIN 6350</b>	Dim.	<b>FL125</b>	<b>FL160</b>	<b>FL260</b>	<b>FL330</b>
	A mm	<b>160</b>	<b>200</b>	<b>315</b>	<b>400</b>
	B mm	<b>140</b>	<b>176</b>	<b>286</b>	<b>362</b>
<b>H6</b>	C mm	<b>125</b>	<b>160</b>	<b>260</b>	<b>330</b>
	D mm	<b>42</b>	<b>55</b>	<b>103</b>	<b>136</b>
	E mm	<b>4</b>	<b>4</b>	<b>5</b>	<b>5</b>
	F mm	<b>68</b>	<b>78</b>	<b>96,2</b>	<b>108</b>
	G mm	<b>53</b>	<b>54</b>	<b>73</b>	<b>92</b>
	G <sub>1</sub> mm	<b>32</b>	<b>29</b>	<b>41</b>	<b>55</b>
	G <sub>2</sub> mm	<b>20</b>	<b>25</b>	<b>32</b>	<b>36</b>
	L mm	<b>70</b>	<b>85</b>	<b>125</b>	<b>145</b>
<b>Front mounting</b>	M <sub>1</sub> mm	<b>3xM10</b>	<b>3xM10</b>	<b>3xM16</b>	<b>3xM16</b>
	Q mm	<b>11</b>	<b>11</b>	<b>14</b>	<b>17</b>
	a °	<b>102°</b>	<b>42°</b>	<b>42°</b>	<b>45°</b>
<b>Max speed</b>	giri/min.	<b>4500</b>	<b>4000</b>	<b>2800</b>	<b>2000</b>
<b>Torque M max</b>	N•m	<b>120</b>	<b>160</b>	<b>200</b>	<b>280</b>
<b>Weight (w. jaws)</b>	kg	<b>11,2</b>	<b>20</b>	<b>50</b>	<b>90</b>
<b>Moment of inertia</b>	kgm <sup>2</sup>	<b>0,03</b>	<b>0,10</b>	<b>0,60</b>	<b>1,80</b>

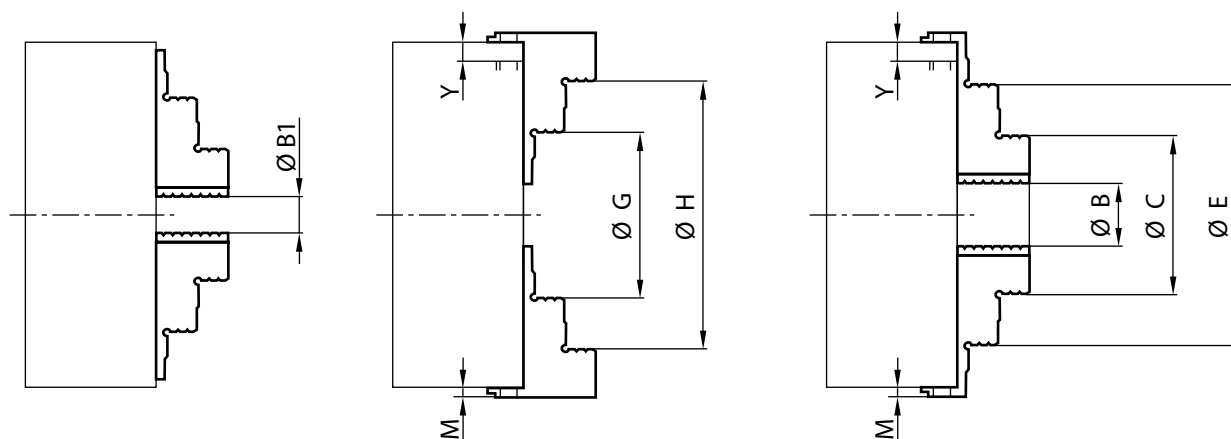

Chuck		SGSF 160-42	SGSF 200-55	SGSF 315-103	SGSF 400-136
Suggested clamping diameters at max. clamping force					
<b>Monoblock jaws</b>	B mm	<b>19-56</b>	<b>22-75</b>	<b>58-115</b>	<b>77-162</b>
	G mm	<b>64-101</b>	<b>78-130</b>	<b>129-199</b>	<b>169-254</b>
	H mm	<b>113-150</b>	<b>146-198</b>	<b>226-296</b>	<b>295-380</b>
	C mm	<b>57-94</b>	<b>68-121</b>	<b>128-184</b>	<b>149-234</b>
	E mm	<b>109-146</b>	<b>136-189</b>	<b>212-281</b>	<b>275-360</b>
	Y mm	<b>0</b>	<b>4</b>	<b>9</b>	<b>16</b>
	M mm	<b>18</b>	<b>22</b>	<b>25</b>	<b>26</b>
Min. clamping diameters with clamping force reduced by 40%					
		<b>3</b>	<b>4</b>	<b>10</b>	<b>10</b>
<b>No. of scroll teeth</b>		<b>2</b>	<b>3</b>	<b>5</b>	<b>5</b>
<b>No. of meshing scroll teets for safety clamping</b>		<b>2</b>	<b>3</b>	<b>5</b>	<b>5</b>

- For max. speed and max. clamping, all teeth shall be meshing.
- For meshing teeth control towards outside dimension (M) toward inside dimension (Y).
- For features exceeding these limits ±16 mm on diameter, shall be reduced by 25%.
- **ATTENTION: CLAMPING DIAMETERS HAVE BEEN CALCULATED WITH A.M. MESHING TEETH.**

Chuck		SGSF 160-42	SGSF 200-55	SGSF 315-103	SGSF 400-136
Accessories		Codici			
<b>Set-3 GRC</b>		<b>03 65 16 30</b>	<b>03 65 20 30</b>	<b>03 65 31 30</b>	<b>03 65 40 30</b>
<b>Set-3 Soft jaws</b>		<b>03 60 16 30</b>	<b>03 60 20 30</b>	<b>03 60 31 30</b>	<b>03 60 40 30</b>
<b>Set-3 ins. jaws Dx</b>		<b>03 55 16 30</b>	<b>03 55 20 30</b>	<b>03 55 31 30</b>	<b>03 55 40 30</b>
<b>Set-3 ins. jaws Sx</b>		<b>03 56 16 30</b>	<b>03 56 20 30</b>	<b>03 56 31 30</b>	<b>0356 40 30</b>
<b>Set-3 Rev. jaws</b>		<b>03 63 16 30</b>	<b>03 63 20 30</b>	<b>03 63 31 30</b>	<b>03 63 40 30</b>
<b>Key</b>		<b>02 71 17 00</b>		<b>02 71 31 00</b>	<b>02 71 40 00</b>

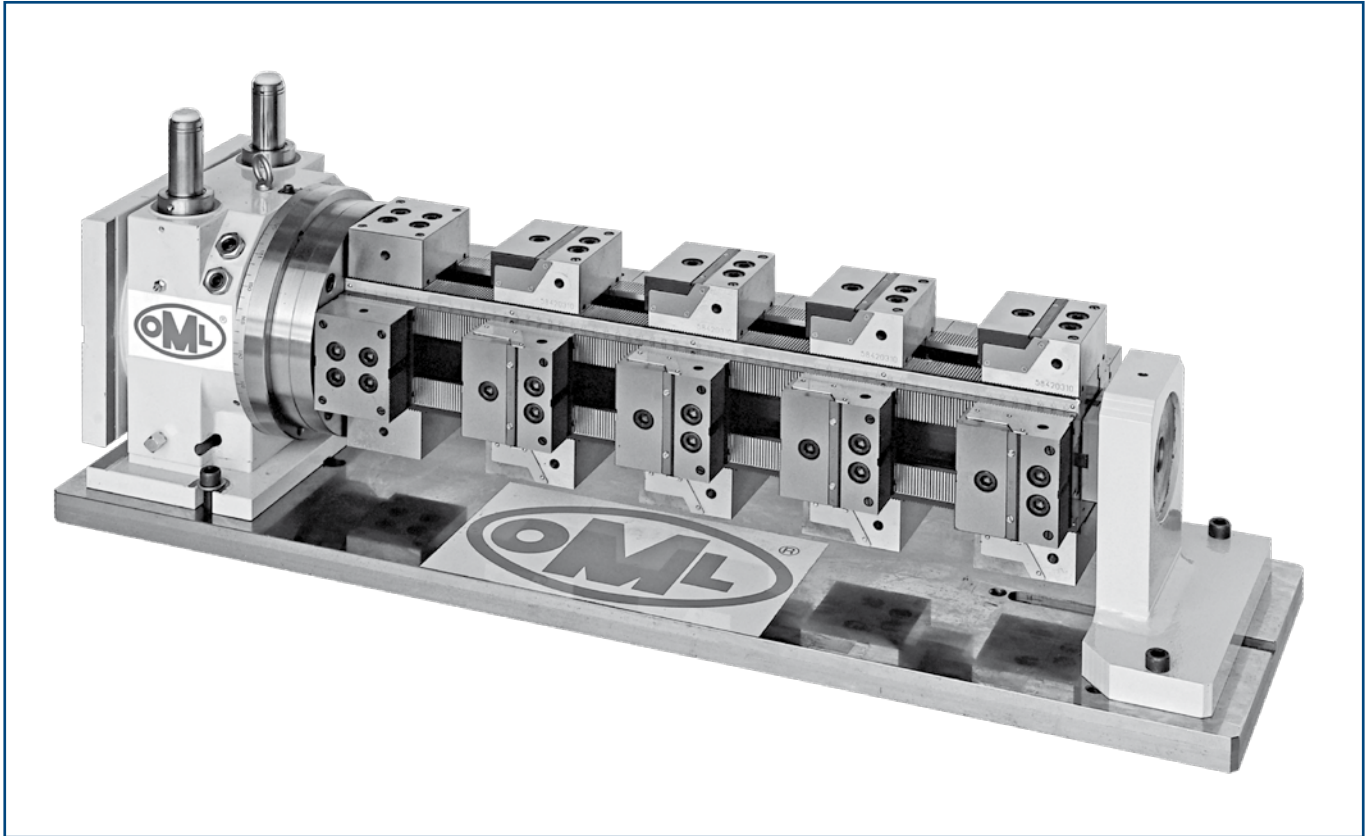

### The example shows:

- TOUCHDEX table
- Column CIVI 2000 (General catalogue OML group 6)
- Moveable jaws set CIVI 2000 (General catalogue OML group 6)



### The example shows:

- TOUCHDEX table with manual chuck