

NOBEL CHUCK

KAVATA TEC

# NOBEL CHUCK GENERAL CATALOG

CE2608

**NOBEL CHUCK**

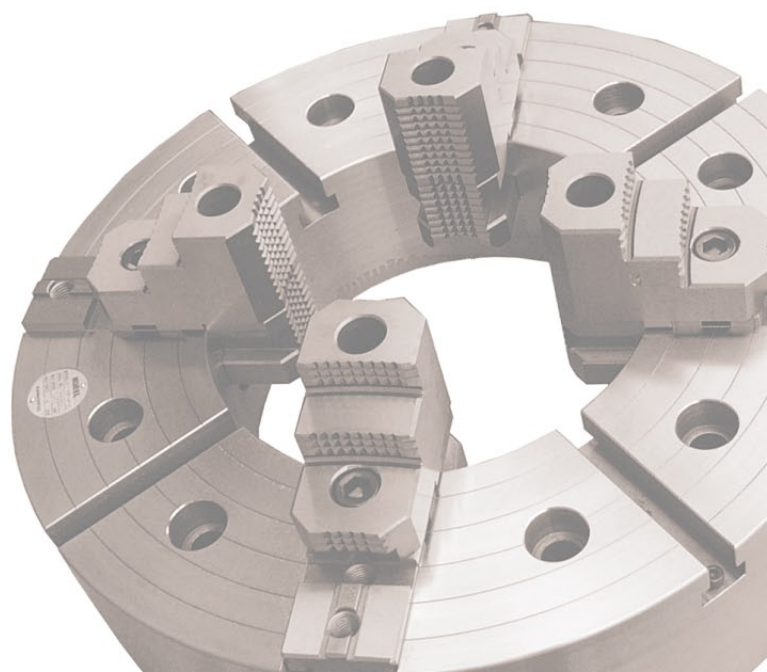



KAWATATEC has manufactured and sold highly valued peripheral machine tool devices around the world since 1933. KAWATATEC, on such a scale, has established a system that focuses 100% on the needs of its customers, through the functions of design and production to sales and services.

### 3 PRODUCT GROUPS IN KAWATATEC

#### NOBEL CHUCK

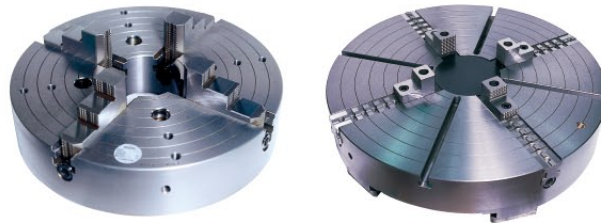

#### TOUCHDEX AND MACHINING CENTER ACCESSORIES

For product information, please refer to the "TOUCHDEX and Machining center accessories" catalog.

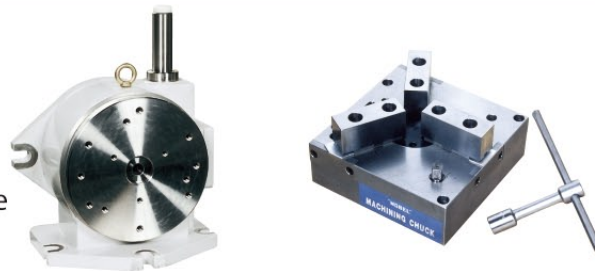

#### PALLET CHANGER & TOOL CHANGER

These products are sold under the brand name of the machine tools manufacturer.

For more product information, please contact Kawatatec directly.



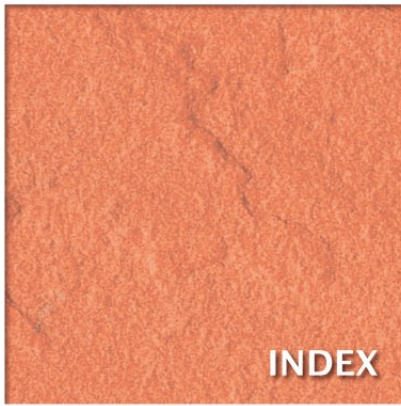

## INDEX

- 1 4-JAW INDEPENDENT CHUCKS (SERIES 46)
- 2 MASTER JAW (SERIES 46DJ)
- 3 4-JAW INDEPENDENT CHUCKS (SERIES 44)
- 4 4-JAW INDEPENDENT CHUCKS (SERIES 41/42)
- 5 4-JAW INDEPENDENT CHUCKS (SERIES IDV/IDK)
- 6 4-JAW INDEPENDENT CHUCKS (Clamp screw included type)
  
- 7 3-JAW SELF-CENTERING CHUCKS (SERIES SC)
- 8 3-JAW SELF-CENTERING CHUCKS (SERIES NST)
- 9 4/6-JAW SELF-CENTERING CHUCKS (SERIES TC)
- 10 3-JAW SELF-CENTERING CHUCKS (SERIES TA)
- 10 PLATES
- 11 3-JAW SELF-CENTERING CHUCKS (SERIES 31/32)
- 12 3-JAW SELF-CENTERING CHUCKS (SERIES SRK)
- 13 3/6-JAW SELF-CENTERING CHUCKS (SERIES TM)
- 14 5-JAW SELF-CENTERING CHUCKS (SERIES PH)
  
- 15 SPINDLE NOSE AND CHUCK INSTALLATION
- 16 SPARE PARTS
  
- 19 SOFT BLANK TOP JAWS
- 20 JAW LOCK (SERIES JL)
- 21 BORING MILL JAWS (SERIES BM)
  
- 23 POWER WRENCHES AND POWER WRENCH CHUCKS (SERIES 36)
- 25 3/6-JAW POWER CHUCKS (SERIES CVH)
- 26 POWER CHUCKS WITH BM JAWS (SERIES CVB)
- 27 4-JAW COMBINATION CHUCKS (SERIES CVA)
- 28 3-JAW POWER CHUCKS (SERIES CV)
- 29 3-JAW POWER CHUCKS (SERIES CLK)
- 29 6-JAW(3+3) POWER CHUCKS (SERIES CVF)
- 30 4-JAW(2+2) POWER CHUCKS (SERIES 4HA)
- 31 6-JAW FLOATING CHUCKS (SERIES FLC/FCH)
- 33 POWER CHUCKS WITH EXTRA LARGE BORE THUROUGH HOLE (SERIES NHR)
- 34 STATIONARY CHUCKS (SERIES ASM)
- 35 COMPACT SIZED HYDRAULIC CYLINDER HS2050SC
- 35 DOUBLE ROTARY CYLINDER (HW)
  
- 36 CHUCK PALLETS FOR MC AND VERTICAL LATHE
- 36 PALLET CHANGER FOR VERTICAL LATHE
  
- 37 WELDING POSITIONER CHUCKS (SERIES WY)
- 38 WELDING POSITIONER CHUCKS (SERIES WPS/WP)
- 39 AUTOMATIC OPERATED PIPE CATHETER
- 40 CENTER DRILL MACHINE
- 41 2-JAW INDEX CHUCKS (SERIES 15)
- 42 2-JAW INDEX POWER CHUCKS (SERIES 15)
  
- 43 SPECIAL CHUCKS
- 47 MACHINING CENTER ACCESSORIES
- 48 PALLET CHANGER / TOOL CHANGER

## FOR ADAPTOR MOUNTING

- Installed on the lathe spindle nose after installation of a back plate
- Cast iron body
- Jig installation is safety-designed by adopting tapped holes

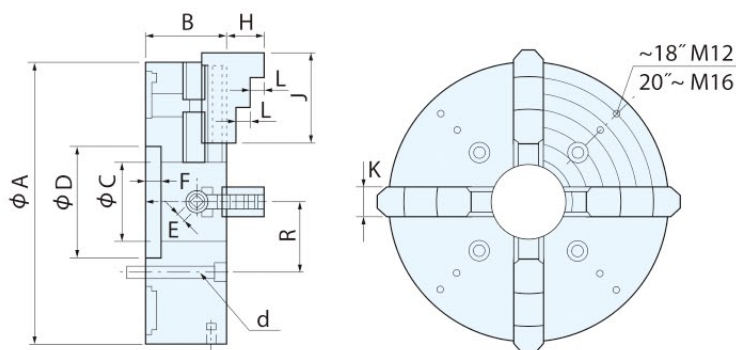

Chuck Size	No.	A	B	C	D <sub>H7</sub>	E	F	H	J	K	L	R	d	Weight (kg)
12	4612 FC	300	90	70	110	12	18	45	112	35	18	66.7	4-M12	39
14	4614 FC	350	100	95	140	12	20	45	112	35	18	85.7	4-M16	49
16	4616 FC	400	100	100	140	14	20	55	132	40	22	85.7	4-M16	64
18	4618 FC	450	105	125	200	14	21	55	132	40	22	117.5	4-M20	86
20	4620 FC	500	110	125	200	14	21	65	149	45	27	117.5	4-M20	117
24	4624 FC	600	120	125	200	15	21	70	159	50	28	117.5	8-M20	164
28	4628 FC	700	130	140	200	16	21	90	190	55	32	117.5	8-M20	225
30	4630 FC	750	140	140	200	16	21	90	190	55	32	117.5	8-M20	275
32	4632 FC	810	140	180	200	26 (Hex.)	21	100	200	60	35	117.5	8-M20	320

※Chucks in a size 28 or larger have a T-slot between jaws. (No tapped holes)

## FOR DIRECT MOUNTING

- Directly installed (JIS/ASA) short tapered type
- Cast iron body
- Jig installation is safety-designed by adopting tapped holes

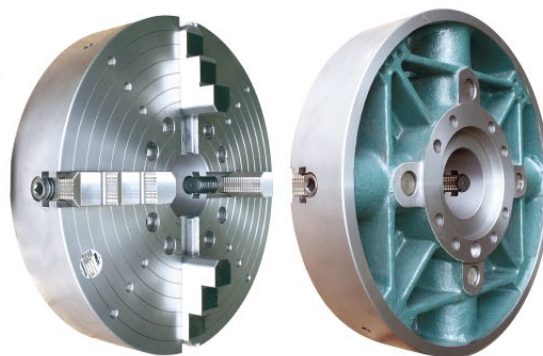
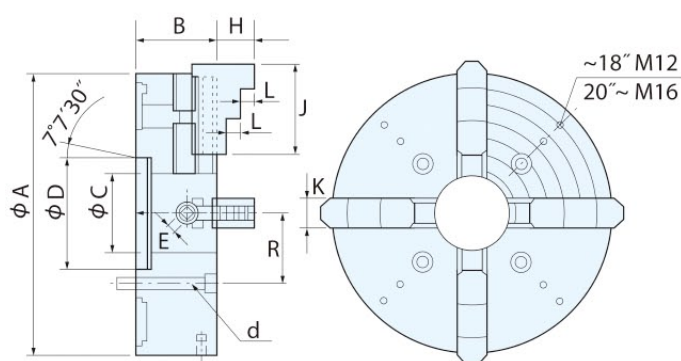

Chuck Size	Spindle Nose	No.	A	B	C	D <sub>H7</sub>	E	H	J	K	L	R	d	Weight (kg)
12	A1- 6	4612 A 6	300	90	70	106.375	12	45	112	35	18	66.7	4-M 12	39
14	A2- 6	4614 A 6	350	100	95	106.375	12	45	112	35	18	66.7	4-M 12	49
16	A2- 6	4616 A 6	400	100	100	106.375	14	55	132	40	22	66.7	8-M 12	64
14	A1- 8	4614 A 8	350	100	95	139.719	12	45	112	35	18	85.7	4-M 16	49
16	A1- 8	4616 A 8	400	100	100	139.719	14	55	132	40	22	85.7	4-M 16	64
18	A2- 8	4618 A 8	450	105	125	139.719	14	55	132	40	22	85.7	4-M 16	87
20	A2- 8	4620 A 8	500	110	125	139.719	14	65	149	45	27	85.7	4-M 16	117
24	A2- 8	4624 A 8	600	120	125	139.719	15	70	159	50	28	85.7	8-M 16	164
18	A1-11	4618 A 11	450	105	125	196.869	14	55	132	40	22	117.5	4-M 20	87
20	A2-11	4620 A 11	500	110	125	196.869	14	65	149	45	27	117.5	4-M 20	117
24	A2-11	4624 A 11	600	120	125	196.869	15	70	159	50	28	117.5	8-M 20	164

※For installation tapers other than above, prepare the tapers so as to be flanged.

■ PERFORMANCE TABLE

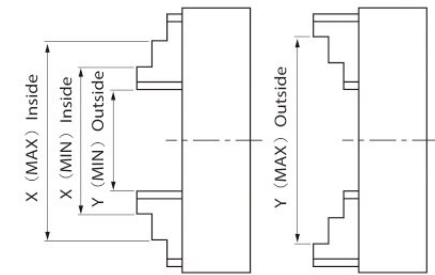

LINEAR FORM (12"~24")

ROUND FORM (28"~)

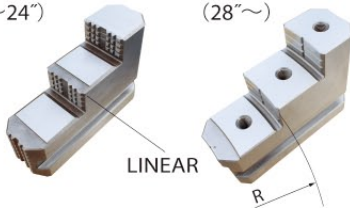

Chuck Size	No.	Gripping Force		Gripping Range		Max. Speed min <sup>-1</sup> (r.p.m)
		Max. Wrench Torque N · m (kgf · m)	Per One Jaw kN (kgf)	Outside MIN~MAX (mm)	Inside MIN~MAX (mm)	
12	4612FC, 4612A6	176 (18)	19 (2000)	25~265	110~265	1800
14	4614FC, 4614A6, 4614A8	196 (20)	21 (2200)	25~310	110~310	1600
16	4616FC, 4616A6, 4616A8	245 (25)	23 (2400)	25~360	115~350	1450
18	4618FC, 4618A8, 4618A11	245 (25)	23 (2400)	25~410	115~390	1300
20	4620FC, 4620A8, 4620A11	294 (30)	27 (2800)	30~450	130~435	1150
24	4624FC, 4624A8, 4624A11	314 (32)	28 (2900)	50~550	140~530	950
28	4628FC, 442813, 442814	343 (35)	31 (3200)	60~640	160~610	700
30	4630FC, 443013, 443014	343 (35)	31 (3200)	60~700	160~650	650
32	4632FC, 443214, 443215	392 (40)	32 (3300)	80~750	200~730	600
36	443614	441 (45)	36 (3700)	80~840	200~800	530
40	444014, 444015	441 (45)	36 (3700)	100~920	200~890	480
47	444714, 444715	490 (50)	40 (4100)	100~1100	220~1070	360
55	445514, 445515	539 (55)	44 (4500)	150~1270	270~1225	300
59	445914, 445915	539 (55)	44 (4500)	200~1370	350~1325	270
63	446314, 446315	539 (55)	44 (4500)	300~1470	450~1425	240
71	447115	588 (60)	49 (5000)	450~1620	650~1640	210

## MASTER JAW (OPTIONAL)

SERIES 46DJ

Adoption of soft jaws is enabled by changing a solid jaw to this master jaw (optional).

FOR INDEPENDENT CHUCK

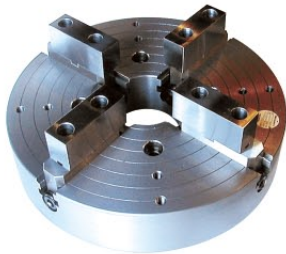

MASTER JAW

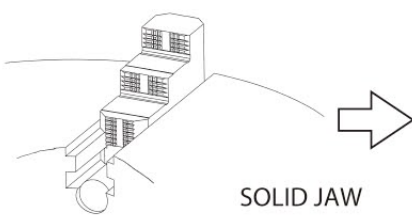
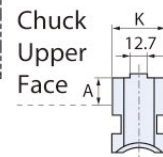
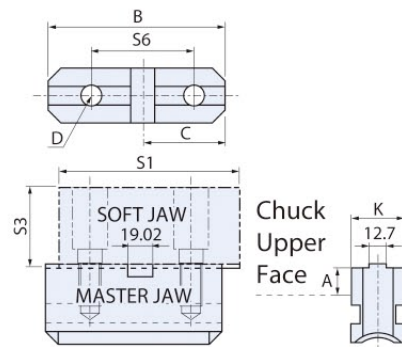

SOLID JAW

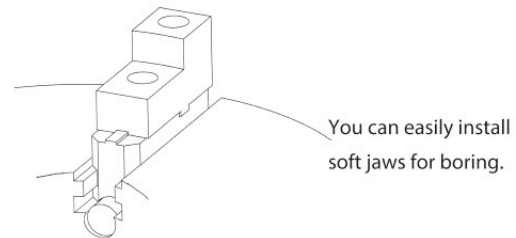
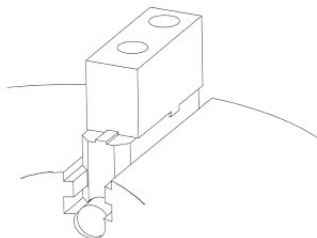

MODEL	Chuck No.	MASTER JAW					SOFT JAW				Unit (mm)	
		A	B	C	D	K	No.	S1	S3	S6	No. x S3	Mounting Bolt(8pcs.)
46 DJ 12	4612FC, 4612A6	15	112	52	M 12	35	SJ-115	115	49	63.5	SJ-115 x 90	M12 x 30
	4614FC, 4614A6, 4614A8											
46 DJ 16	4616FC, 4616A6, 4616A8	20	132	61	M 16	40	SJ-135	135	60	76.2	SJ-135 x 120	M16 x 35
	4618FC, 4618A8, 4618A11											
46 DJ 20	4620FC, 4620A8, 4620A11	20	150	65	M 16	45	SJ-135	135	60	76.2	SJ-135 x 120	M16 x 35
46 DJ 24	4624FC, 4624A8, 4624A11	25	160	70	M 20	50	SJ-150	150	70	76.2	SJ-150 x 120	M20 x 40
46 DJ 28	4628FC, 442813, 442814	25	190	73	M 20	55	SJ-155	155	80	76.2	SJ-155 x 140	M20 x 40
	4630FC, 443013, 443014											
46 DJ 32	4632FC, 443214, 443215	25	200	73	M 20	60	SJ-155	155	80	76.2	SJ-155 x 140	M20 x 40

※ Things to keep in mind when using soft jaws : Please consider the jaw edge shape, higher jaw, flaw prevention, and safety, etc., before use.

## LARGE-SIZED TYPE

- Directly installed (JIS/ASA) short tapered type
- Replaceable solid jaw type
- A stopper bolt provided at the T-slot end

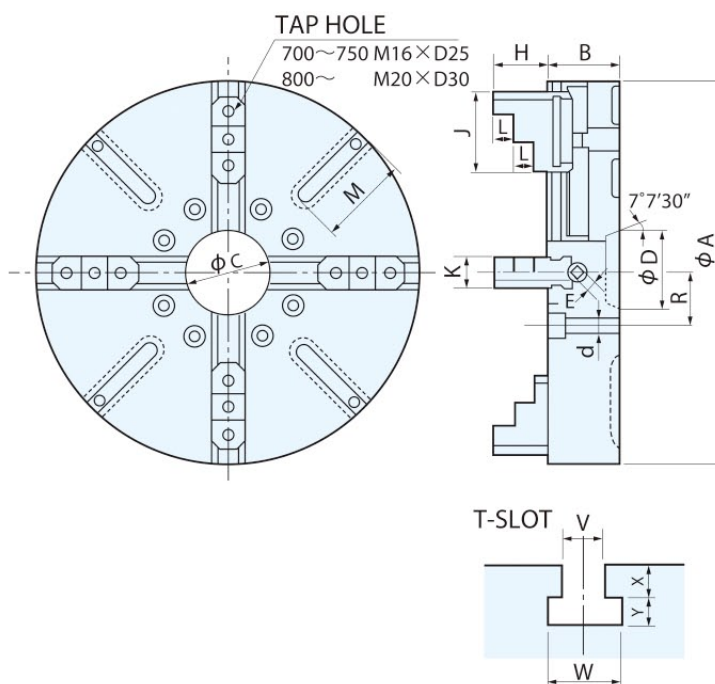
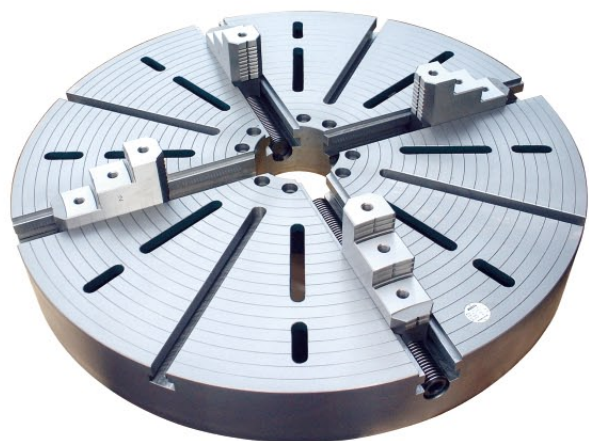

Chuck Size	V	W	X	Y
28 (700) ~30 (750)	20	34	20	13.5
32 (800) ~40 (1000)	24	42	24	18
47 (1200) ~	28	48	28	20

Chuck Size	Spindle Nose	No.	Unit (mm)												Weight (kg)
			A	B	C	D	E	H	J	K	L	M	R	d	
28	A <sub>1</sub> - 8	442813	700	130	110	139.719	16 (Quad.)	90	190	55	32	200	85.7	4-M16	240
30	A <sub>2</sub> - 8	443013	750	140	120	//	16 (Quad.)	90	190	55	32	175	//	//	285
28	A <sub>1</sub> -11 A <sub>2</sub> -11	442814	700	130	140	196.869	16 (Quad.)	90	190	55	32	180	117.5	8-M20	235
30		443014	750	140	140	//	16 (Quad.)	90	190	55	32	175	//	//	280
32		443214	810	140	180	//	26 (Hex.)	100	200	60	35	235	//	//	320
36		443614	915	150	165	//	26 (Hex.)	100	200	60	35	260	//	//	460
40		444014	1000	160	180	//	26 (Hex.)	100	200	60	35	320	//	//	485
47		444714	1200	160	180	//	26 (Hex.)	110	230	80	40	400	//	//	690
55		445514	1400	160	180	//	26 (Hex.)	110	230	80	40	420	//	//	970
59		445914	1500	170	180	//	26 (Hex.)	110	230	80	40	480	//	//	1080
63		446314	1600	190	180	//	26 (Hex.)	110	230	80	40	520	//	//	1450
32		A <sub>1</sub> -15 A <sub>2</sub> -15	443215	800	200	200	285.775	26 (Hex.)	110	230	80	40	150	165.1	8-M22
40	444015		1000	200	180	//	26 (Hex.)	110	230	80	40	250	//	//	710
47	444715		1200	200	200	//	26 (Hex.)	110	230	80	40	350	//	//	1050
55	445515		1400	200	200	//	26 (Hex.)	110	230	80	40	420	//	//	1100
59	445915		1500	200	200	//	26 (Hex.)	110	230	80	40	480	//	//	1200
63	446315		1600	200	200	//	26 (Hex.)	110	230	80	40	520	//	//	1480
71	447115		1800	220	200	//	26 (Hex.)	160	300	80	55	600	//	//	2100

※Manufacture of chucks in sizes other than the above is available.

## FORGED STEEL BODY

- Directly installed (JIS/ASA) short tapered type
- Standard 2-piece tongue and groove jaws
- One set of hard top jaws included (Soft jaws not included)
- A stopper bolt provided at the T-slot end

410 : HEAVY DUTY  
 420 : MEDIUM DUTY  
 411,421 : TOP JAW UNC TYPE

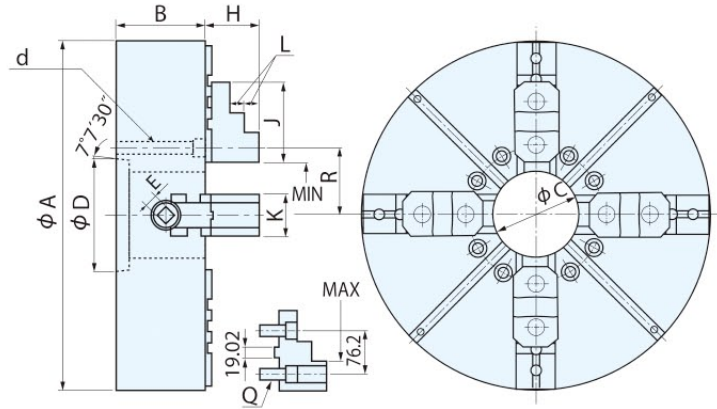
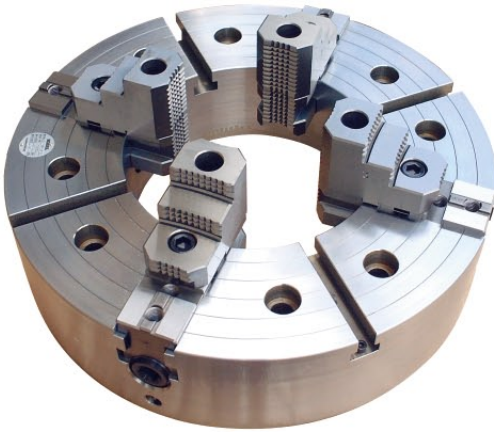

※1 : Dimensions   : metric,   : inch.    ※2 : Dimensions in brackets ( ) are Max. thru-hole diameter which can be machined.  
 ※3 : Bolt   : for 410, 420 model    Bolt   : for 411, 421 model

Unit (mm)

MODEL	Spindle Nose	A		B		C		D		Gripping Dia		R		Weight			
		(mm)	(inch)	(mm)	(inch)	(mm)	(inch)	(mm)	(inch)	MIN (mm)	MAX (inch)	(mm)	(inch)	(kg)	(lb)		
420-18-A8	A1 · A2- 8	457	18	127	5.0	115	4.5	139.7	5.5	35	1.4	430	17	85.7	3.37	165	365
420-18-A11	A1 · A2-11	457	18	127	5.0	152	6.0	196.9	7.8	35	1.4	430	17	117.5	4.63	156	345
420-21-A8	A1 · A2- 8	535	21	127	5.0	115	4.5	139.7	5.5	35	1.4	500	20	85.7	3.37	225	497
410-21-A11	A1 · A2-11	535	21	146	5.7	152 (160)	6.0 (6.3)	196.9	7.8	45	1.8	490	19	117.5	4.63	240	530
410-21-A15	A1 · A2-15	535	21	146	5.7	204	8.0	285.8	11.3	74	2.9	490	19	165.1	6.5	230	508
410-24-A11	A1 · A2-11	610	24	155	6.1	172 (185)	6.8 (7.3)	196.9	7.8	55	2.2	560	22	117.5	4.63	342	756
410-24-A15	A1 · A2-15	610	24	155	6.1	241 (259)	9.5 (10.2)	285.8	11.3	110	4.3	560	22	165.1	6.5	310	685
410-24-A20	A1 · A2-20	610	24	155	6.1	318	12.5	412.8	16.3	185	7.3	560	22	231.8	9.13	278	614
420-28-A11	A1 · A2-11	710	28	134	5.3	172	6.8	196.9	7.8	45	1.8	680	27	117.5	4.63	390	862
410-28-A15	A1 · A2-15	710	28	155	6.1	268 (275)	10.6 (10.8)	285.8	11.3	125	4.9	660	26	165.1	6.5	430	950
410-28-A20	A1 · A2-20	710	28	155	6.1	318	12.5	412.8	16.3	175	6.9	660	26	231.8	9.13	395	873
420-32-A11	A1 · A2-11	810	32	134	5.3	172	6.8	196.9	7.8	45	1.8	780	31	117.5	4.63	510	1127
410-32-A15	A1 · A2-15	810	32	165	6.5	268 (275)	10.6 (10.8)	285.8	11.3	125	4.9	760	30	165.1	6.5	595	1315
410-32-A20	A1 · A2-20	812	32	165	6.5	318 (370)	12.5 (14.6)	412.8	16.3	175	6.9	760	30	231.8	9.13	565	1249
410-36-A15	A1 · A2-15	915	36	175	6.9	268 (275)	10.6 (10.8)	285.8	11.3	125	4.9	860	34	165.1	6.5	820	1812
410-36-A20	A1 · A2-20	915	36	175	6.9	318 (370)	12.5 (14.6)	412.8	16.3	175	6.9	860	34	231.8	9.13	790	1746
410-42-A15	A1 · A2-15	1067	42	175	6.9	268 (275)	10.6 (10.8)	285.8	11.3	125	4.9	1010	40	165.1	6.5	1150	2542
410-42-A20	A1 · A2-20	1067	42	175	6.9	318 (370)	12.5 (14.6)	412.8	16.3	175	6.9	1010	40	231.8	9.13	1120	2475

MODEL	E		Q *3		J		K		H		d	Wrench Torque N · m (kgf · m)	Gripping Force Per Jaw kN (kgf)	Max. Speed min <sup>-1</sup> (r.p.m)
	(mm)	(inch)	(Bolt For Top Jaws)		(mm)	(inch)	(mm)	(inch)	(mm)	(inch)				
420-18-A8	16	0.63	M20	UNC 3/4	135	5.3	50	1.97	75	2.95	4-M16	314(32)	29(3000)	1200
420-18-A11	16	0.63	M20	UNC 3/4	135	5.3	50	1.97	75	2.95	4-M20	314(32)	29(3000)	1200
420-21-A8	16	0.63	M20	UNC 3/4	135	5.3	50	1.97	75	2.95	4-M16	314(32)	29(3000)	1000
410-21-A11	19	0.75	M20	UNC 3/4	135	5.3	60	2.36	75	2.95	8-M20	343(35)	31(3200)	1000
410-21-A15	19	0.75	M20	UNC 3/4	135	5.3	60	2.36	75	2.95	8-M22	343(35)	31(3200)	1000
410-24-A11	22	0.87	M20	UNC 3/4	140	5.5	75	2.95	92	3.62	8-M20	392(40)	36(3700)	850
410-24-A15	22	0.87	M20	UNC 3/4	140	5.5	75	2.95	92	3.62	8-M22	392(40)	36(3700)	850
410-24-A20	22	0.87	M20	UNC 3/4	140	5.5	75	2.95	92	3.62	8-M24	392(40)	36(3700)	850
420-28-A11	19	0.75	M20	UNC 3/4	135	5.3	60	2.36	75	2.95	8-M20	392(40)	36(3700)	650
410-28-A15	22	0.87	M22	UNC 7/8	140	5.5	75	2.95	92	3.62	8-M22	441(45)	40(4100)	650
410-28-A20	22	0.87	M22	UNC 7/8	140	5.5	75	2.95	92	3.62	8-M24	441(45)	40(4100)	650
420-32-A11	19	0.75	M20	UNC 3/4	135	5.3	60	2.36	75	2.95	8-M20	392(40)	36(3700)	550
410-32-A15	22	0.87	M22	UNC 7/8	140	5.5	75	2.95	92	3.62	8-M22	441(45)	40(4100)	550
410-32-A20	22	0.87	M22	UNC 7/8	140	5.5	75	2.95	92	3.62	8-M24	441(45)	40(4100)	550
410-36-A15	22	0.87	M22	UNC 7/8	140	5.5	75	2.95	92	3.62	8-M22	490(50)	44(4500)	500
410-36-A20	22	0.87	M22	UNC 7/8	140	5.5	75	2.95	92	3.62	8-M24	490(50)	44(4500)	500
410-42-A15	22	0.87	M22	UNC 7/8	140	5.5	75	2.95	92	3.62	8-M22	490(50)	44(4500)	400
410-42-A20	22	0.87	M22	UNC 7/8	140	5.5	75	2.95	92	3.62	8-M24	490(50)	44(4500)	400

※For master jaw dimensions and use of soft jaw, refer to page 19.    ※Manufacture of chucks in sizes other than the above is available.

## 4-JAW INDEPENDENT CHUCKS WITH COVER

- Cast iron body
- With chip covers
- One set of hard top jaws are included  
(Soft jaws not included)

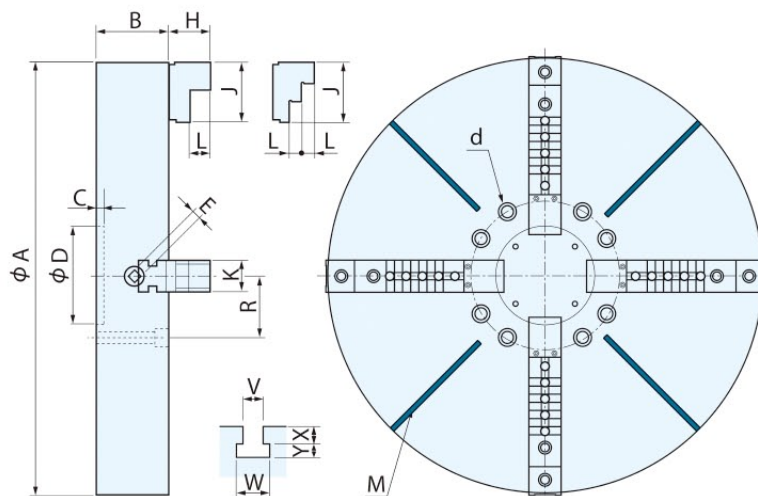

Unit (mm)

MODEL	A	B	C	D(H7)	E	H	J	K	L	Jaw Type	M	R	d	V	W	X	Y
IDV 450 ST	450	105	21	200	14	75	135	45	17.5	3-Step	8-M12	117.5	4-M20	-	-	-	-
IDV 500 ST	500	110	21	200	14	75	135	45	17.5	3-Step	8-M16	117.5	4-M20	-	-	-	-
IDV 600 ST	600	120	21	200	15	83	135	49	40	2-Step	12-M16	117.5	8-M20	-	-	-	-
IDK 700 ST	700	130	21	200	16	75	135	60	17.5	3-Step	T-Slot	117.5	8-M20	20	34	20	14
IDK 800 ST	800	160	20	200	19	92	140	69	46	2-Step	T-Slot	165.1	8-M24	24	42	24	18
IDK 915 ST	915	160	20	200	19	92	140	69	46	2-Step	T-Slot	165.1	8-M24	24	42	24	18
IDK 1000 ST	1000	160	20	200	19	92	140	69	46	2-Step	T-Slot	165.1	8-M24	24	42	24	18
IDK 1200 ST	1200	200	25	200	19	100	170	79	50	2-Step	T-Slot	165.1	8-M24	28	48	28	20
IDK 1400 ST	1400	200	25	280	26 (Hex.)	100	170	79	50	2-Step	T-Slot	165.1	8-M24	28	48	28	20
IDK 1500 ST	1500	200	25	280	26 (Hex.)	100	170	79	50	2-Step	T-Slot	165.1	8-M24	28	48	28	20
IDK 1600 ST	1600	200	25	280	26 (Hex.)	100	170	79	50	2-Step	T-Slot	165.1	8-M24	28	48	28	20
IDK 1800 ST	1800	220	25	280	26 (Hex.)	100	170	79	50	2-Step	T-Slot	165.1	8-M24	28	48	28	20

MODEL	Max. Static Gripping Force (Per Jaw) kN (kgf)	Max. Wrench Torque N · m (kgf · m)	Gripping Range		Max. Speed min <sup>-1</sup>	Chuck Weight (kg)	Soft Jaw	Bolt For Top Jaw
			Outside (φ mm) MIN ~ MAX	Inside (φ mm) MIN ~ MAX				
IDV 450 ST	23 (2400)	245 (25)	165 ~ 405	270 ~ 415	1300	87	SJ-135	M16
IDV 500 ST	27 (2800)	294 (30)	190 ~ 430	295 ~ 440	1150	120	SJ-135	M16
IDV 600 ST	28 (2900)	314 (32)	185 ~ 480	310 ~ 455	950	170	SJ-135	M16
IDK 700 ST	31 (3200)	343 (35)	215 ~ 625	325 ~ 640	700	240	SJ-155	M20
IDK 800 ST	34 (3500)	490 (50)	260 ~ 690	400 ~ 660	650	410	SJ-160	M20
IDK 915 ST	36 (3700)	490 (50)	230 ~ 855	375 ~ 820	540	495	SJ-160	M20
IDK 1000 ST	36 (3700)	490 (50)	230 ~ 880	375 ~ 840	470	550	SJ-160	M20
IDK 1200 ST	40 (4100)	490 (50)	260 ~ 1080	420 ~ 1040	360	1050	SJ-170	M22
IDK 1400 ST	44 (4500)	539 (55)	260 ~ 1270	410 ~ 1240	300	1200	SJ-170	M22
IDK 1500 ST	44 (4500)	539 (55)	300 ~ 1370	445 ~ 1340	270	1300	SJ-170	M22
IDK 1600 ST	44 (4500)	539 (55)	400 ~ 1470	545 ~ 1440	240	1580	SJ-170	M22
IDK 1800 ST	49 (5000)	588 (60)	400 ~ 1680	545 ~ 1650	210	2100	SJ-170	M22

\* For master jaw dimensions and use of soft jaw, refer to page 19.  
\* Manufacture of chucks in sizes other than the above is available.

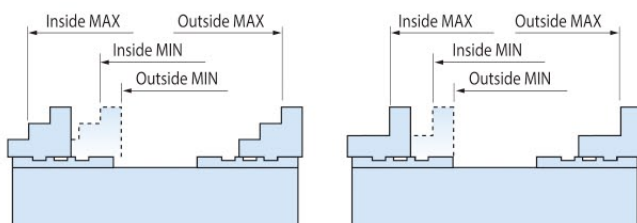



## POWER CLAMP SCREW INCLUDED 4-JAW INDEPENDENT CHUCKS

### MS(Clamp screw included) type

- Large clamping force with a low drive torque
- High reliability, high rigidity
- Easily adjustable stroke
- Simple operability and easy maintenance

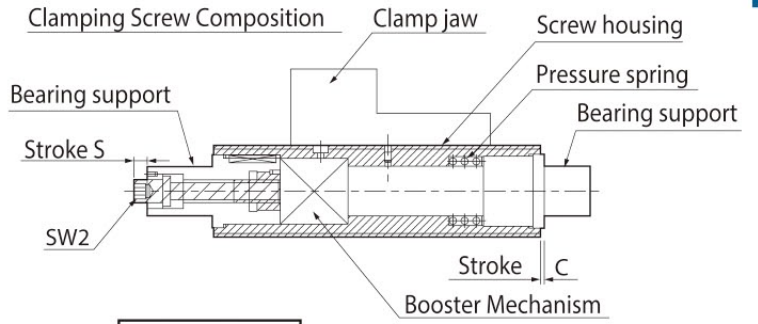

Relationship between clamping force and tightening torque(SW2)

(In the case of MPSD-120)

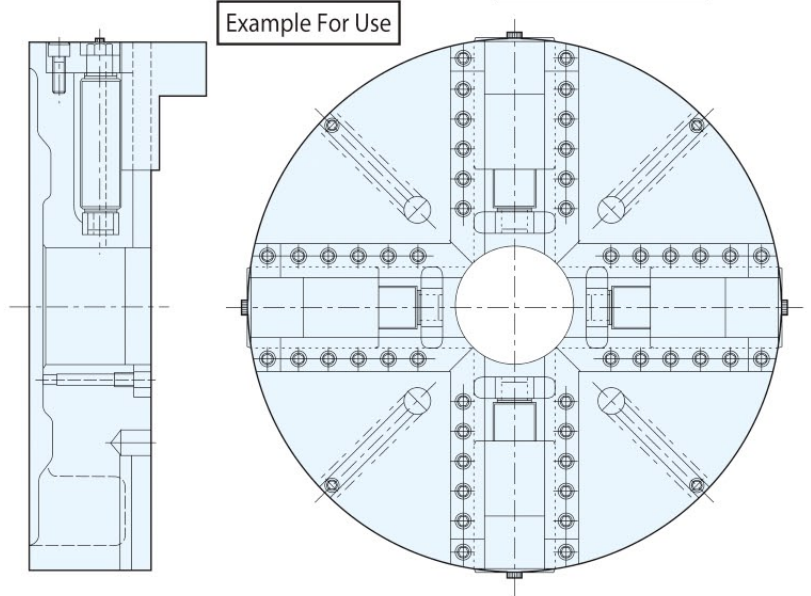
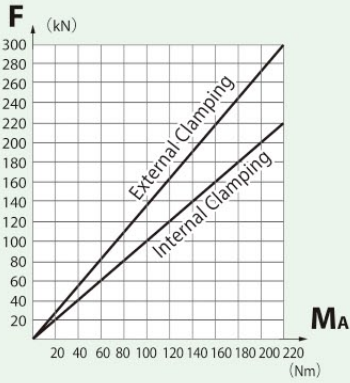

MS size	65	80	100	120	160	200
ISO Trapezoidal Screw	Tr 65×4	Tr 80×5	Tr 100×6	Tr 120×6	Tr 160×8	Tr 200×10
Max. Clamping Force (External) [kN]	150	200	250	300	400	500
Max. Tightening Torque (SW2) [Nm]	80	100	130	160	160	160
Max. Static Load [kN]	250	300	400	600	800	1100
Stroke (C) [mm]	2.5	3	3	3	3	3
Tightening Travel Distance (S) [mm]	15	17	17	17	25	27

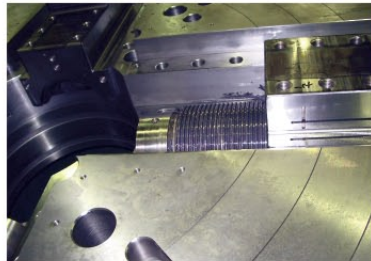
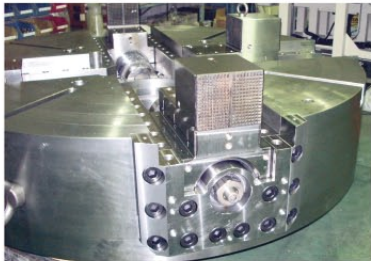

## SOLID JAWS/FOR ADAPTOR MOUNTING TYPE



- Manufactured according to the JIS standard  
Includes one set of heat-treated inside and outside jaws
- Cast iron body

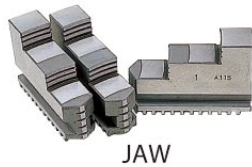

## LC-2 LEVER CHUCK

- Used for table lathes or small-sized
- With inside/outside jaws

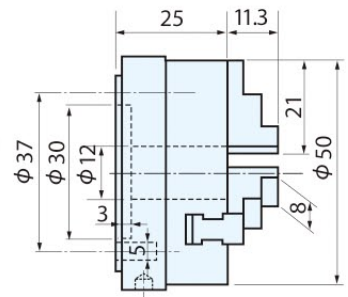
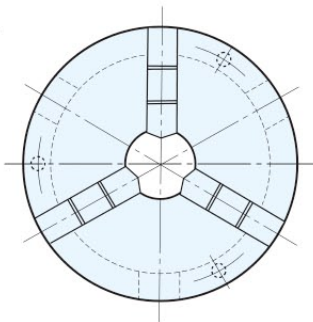
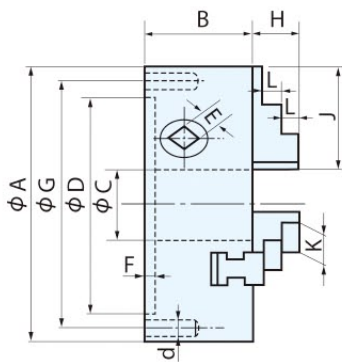

Unit (mm)

Chuck Size	3	4	5	6	7	9	10	12	
MODEL	SC85F	SC110F	SC130F	SC165F	SC190F	SC230F	SC273F	SC310F	
No.	350340	350440	350540	350640	350740	350940	351040	351240	
A	87	112	132	167	192	233	274	310	
B	46	58	60	66	75	82	86	92	
※1 C	16	24(26)	32(34)	44(46)	54(58)	70(75)	90(100)	110(120)	
D	60 <sup>+0.019</sup> <sub>0</sub>	80 <sup>+0.019</sup> <sub>0</sub>	100 <sup>+0.022</sup> <sub>0</sub>	130 <sup>+0.025</sup> <sub>0</sub>	155 <sup>+0.025</sup> <sub>0</sub>	190 <sup>+0.029</sup> <sub>0</sub>	230 <sup>+0.029</sup> <sub>0</sub>	260 <sup>+0.032</sup> <sub>0</sub>	
E	7	8	8	10	11	12	12	14	
F	3	4	4	5	5	6	6	7	
G	73	95	115	147	172	210	250	285	
H	15	18	20	25	30	35	40	45	
J	35	43	53	65	75	87	98	110	
K	11	14	16	19	21	24	28	30	
L	6	7	8	10	12	14	16	17	
d	3-M6×35	3-M8×35	3-M8×35	3-M10×40	3-M10×40	3-M12×45	3-M12×50	3-M12×55	
Gripping Range ※2	Outside	φ2~φ71(86)	φ2~φ90(105)	φ2~φ105(132)	φ3~φ134(163)	φ3~φ152(195)	φ4~φ187(234)	φ5~φ220(274)	φ5~φ252(318)
	Inside	φ22~φ59(74)	φ30~φ80(95)	φ33~φ94(120)	φ43~φ122(151)	φ48~φ150(183)	φ56~φ175(222)	φ63~φ208(262)	φ68~φ238(302)
Max. Wrench Torque N·m(kgf·m)	24.5(2.5)	44.1(4.5)	63.8(6.5)	107.9(11)	117.7(12)	137.3(14)	176.5(18)	196.2(20)	
Max. Static Gripping Force kN(kgf)	10(1020)	17(1750)	24(2450)	31(3170)	31(3200)	37(3800)	46(4700)	55(5600)	
Max. Speed min <sup>-1</sup> (r.p.m)	4050	3700	3200	2500	2100	1900	1600	1400	
GD <sup>2</sup> N·m <sup>2</sup> (kgf·m <sup>2</sup> )	0.069(0.007)	0.196(0.02)	0.490(0.05)	1.28(0.13)	2.45(0.25)	5.69(0.58)	11.2(1.14)	19.6(2.00)	
Chuck Weight kg	1.7	3.3	4.7	8.0	12	19	27	37	

※1 Dimension C in brackets ( ) are Max. thru-hole diameter which can be machined.

※2 Values in ( ) are Max. values which the chucks can grip, but this is not recommended.

## 2-PIECE JAWS/FOR ADAPTOR MOUNTING TYPE

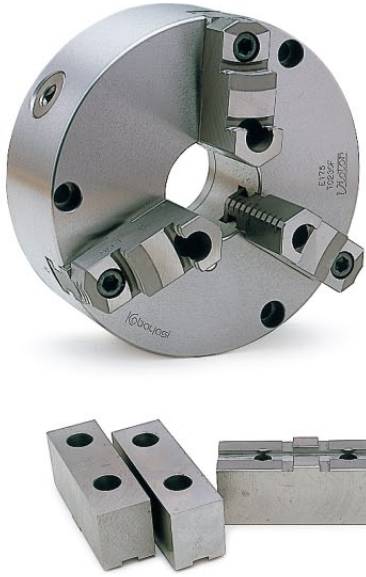

- 2-piece tongue and groove jaws
- One each set of soft jaws and hard top jaws are included
- Cast iron body

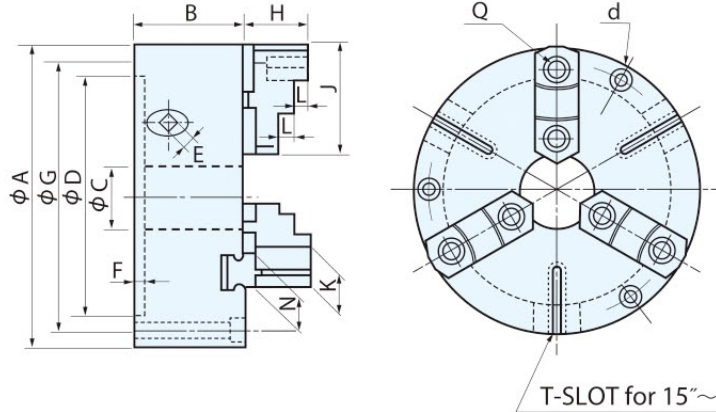

Unit (mm)

MODEL	TC130F	NST 6	NST 7	NST 9	NST 10	NST 12	NST 15	NST 18	NST 21	NST 24	
No.	340540	340640	340740	340940	341040	341240	341540	341840	342140	342440	
A	132	167	192	233	274	310	385	460	535	610	
B	60	66	75	82	86	92	100	114	143	143	
C	32(34)	44(46)	54(58)	70(75)	90(100)	110(120)	130(150)	150(190)	160(197)	180(220)	
D	100 <sup>+0.022</sup> <sub>0</sub>	130 <sup>+0.025</sup> <sub>0</sub>	155 <sup>+0.025</sup> <sub>0</sub>	190 <sup>+0.029</sup> <sub>0</sub>	230 <sup>+0.029</sup> <sub>0</sub>	260 <sup>+0.032</sup> <sub>0</sub>	330 <sup>+0.036</sup> <sub>0</sub>	400 <sup>+0.036</sup> <sub>0</sub>	270 <sup>+0.032</sup> <sub>0</sub>	300 <sup>+0.032</sup> <sub>0</sub>	
E	8	10	11	12	12	14	15	17	22(Hex.)	22(Hex.)	
F	4	5	5	6	6	7	7	8	12	14	
G	115	147	172	210	250	285	355	425	235	260	
H	37	44	46	55	53	59	71	80	82	82	
J	56	68	80	90	95	110	127	130	130	130	
K	23	30	30	35	35	40	43	50	50	50	
L	8	9.5	9.5	12	12	14	15	17	17	17	
N	19	22	25	28	28	30	35	45	50	50	
Q (6pcs.)	M8×20	M10×20	M10×22	M12×25	M12×25	M12×30	M16×35	M20×45	M20×45	M20×45	
d	3-M8×65	3-M10×75	3-M10×80	3-M12×90	3-M12×95	3-M12×100	6-M12×110	6-M16×125	6-M20×140	6-M20×140	
Gripping Range	Outside	φ3~φ104 (134)	φ3~φ135 (170)	φ3~φ153 (206)	φ4~φ190 (242)	φ10~φ229 (277)	φ10~φ258 (322)	φ20~φ329 (394)	φ40~φ367 (478)	φ45~φ422 (508)	φ50~φ514 (614)
	Inside	φ42~φ92 (122)	φ52~φ119 (152)	φ56~φ134 (188)	φ64~φ169 (222)	φ72~φ208 (256)	φ82~φ238 (302)	φ100~φ302 (367)	φ150~φ379 (490)	φ155~φ434 (520)	φ160~φ526 (626)
Max. Wrench Torque N·m(kgf·m)	63.8(6.5)	107.9(11)	117.7(12)	137.3(14)	176.5(18)	196.2(20)	215.8(22)	255.0(26)	313.9(32)	372.7(38)	
Max. Static Gripping Force kN(kgf)	24(2450)	31(3170)	31(3200)	37(3800)	46(4700)	55(5600)	57(5800)	65(6650)	73(7400)	80(8200)	
Max. Speed min <sup>-1</sup> (r.p.m)	2600	2100	1800	1600	1360	1200	980	870	950	850	
GD <sup>2</sup> N·m <sup>2</sup> (kgf·m)	0.490(0.05)	1.28(0.13)	2.45(0.25)	5.69(0.58)	11.18(1.14)	19.6(2.00)	53.2(5.42)	124(12.6)	287(29.3)	488(49.8)	
Chuck Weight kg	5.1	10	14	21	28	38	65	106	182	238	
Soft Jaw	SJ-62	SJ-70	SJ-85	SJ-100	SJ-100	SJ-115	SJ-135	SJ-150	SJ-150	SJ-150	

※Dimension C in brackets ( ) are Max. thru-hole diameter which can be machined.  
 ※For master jaw dimensions and use of soft jaw, refer to page 18-19.

## TC-4F TYPE

- 4-jaw self-centering chuck
- 2-piece tongue and groove jaws
- One set of soft jaws and hard top jaws are included
- For adaptor mounting
- Square (angular) works and cylindrical works can be gripped

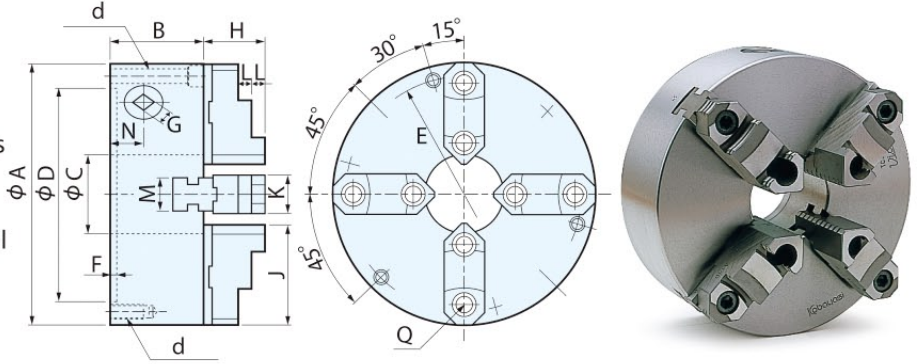

MODEL	No	A	B	C	D	E	F	H	J	K	L	M	N	G	Q	※ R/F	d
TC110F4	4	112	58	24 (26)	80 <sup>+0.019</sup> <sub>0</sub>	95	4	31	45	19	7	16	23.6	8	8-M6×15	R	3-M8×35
TC130F4	5	132	60	32 (34)	100 <sup>+0.022</sup> <sub>0</sub>	115	4	37	56	23	8	19	24.0	8	8-M8×20	R	3-M8×35
TC165F4	6	167	66	44 (46)	130 <sup>+0.025</sup> <sub>0</sub>	147	5	44	68	30	9.5	22	24.6	10	8-M10×20	R	3-M10×40
TC190F4	7	192	75	54 (58)	155 <sup>+0.025</sup> <sub>0</sub>	172	5	46	80	30	9.5	25	27.2	11	8-M10×22	R	3-M10×40
TC230F4	9	233	82	70 (75)	190 <sup>+0.029</sup> <sub>0</sub>	210	6	55	90	35	12	28	29.5	12	8-M12×25	R	3-M12×45
TC273F4	10	274	86	90 (100)	230 <sup>+0.029</sup> <sub>0</sub>	250	6	53	95	35	12	28	30.0	12	8-M12×25	F	3-M12×95
TC310F4	12	310	92	110 (120)	260 <sup>+0.032</sup> <sub>0</sub>	285	7	59	110	40	14	30	32.2	14	8-M12×30	F	3-M12×100
TC385F4	15	385	100	130 (150)	330 <sup>+0.036</sup> <sub>0</sub>	355	7	71	127	43	15	35	32.8	15	8-M16×35	F	3-M12×110
TC460F4	18	460	114	150 (190)	400 <sup>+0.036</sup> <sub>0</sub>	425	8	80	130	50	17	45	38.0	17	8-M20×45	F	3-M16×125

Dimension C in brackets( ) are Max. thru-hole diameter which can be machined.

※R: Rear-side mounting F: Front-side mounting

MODEL	Max. Wrench Torque N · m (kgf · m)	Max. Static Gripping Force kN (kgf)	Gripping Range		Soft Jaw (4 pcs.)	Weight (kg)	GD <sup>2</sup> N · m <sup>2</sup> (kgf · m <sup>2</sup> )	Max. Speed min <sup>-1</sup> (r.p.m)
			Outside $\phi$ mm	Inside $\phi$ mm				
TC110F4	44.1 (4.5)	16 (1660)	2.5~89 (108)	38~78 (97)	SJ-53	3.4	0.294 (0.03)	2700
TC130F4	63.8 (6.5)	23 (2320)	3~104 (134)	43~92 (122)	SJ-62	5.1	0.490 (0.05)	2300
TC165F4	107.9 (11)	30 (3010)	3.5~135 (170)	52~119 (152)	SJ-70	10	1.57 (0.16)	1850
TC190F4	117.7 (12)	30 (3040)	4~153 (206)	57~134 (188)	SJ-85	14	2.84 (0.29)	1600
TC230F4	137.3 (14)	35 (3610)	5~190 (242)	75~169 (220)	SJ-100	21	6.27 (0.64)	1400
TC273F4	176.5 (18)	44 (4460)	10~229 (277)	75~208 (256)	SJ-100	28	12.0 (1.22)	1200
TC310F4	196.2 (20)	52 (5320)	10~258 (322)	113~238 (302)	SJ-115	38	21.2 (2.16)	1050
TC385F4	215.8 (22)	54 (5510)	20~329 (394)	131~302 (367)	SJ-135	65	50.7 (5.17)	850
TC460F4	255.0 (26)	62 (6310)	40~367 (478)	136~379 (490)	SJ-150	106	125 (12.7)	750

Values in ( ) are maximum values which the chucks can grip, but this is not recommended.

For master jaw dimensions and use of soft jaw, refer to page 18-19.

## TC-6F TYPE

- 6-jaw self-centering chuck
- 2-piece tongue and groove jaws
- One set of soft jaws and hard top jaws are included
- For adaptor mounting Front-side mounting
- Pipe-shaped works can be gripped with little strain

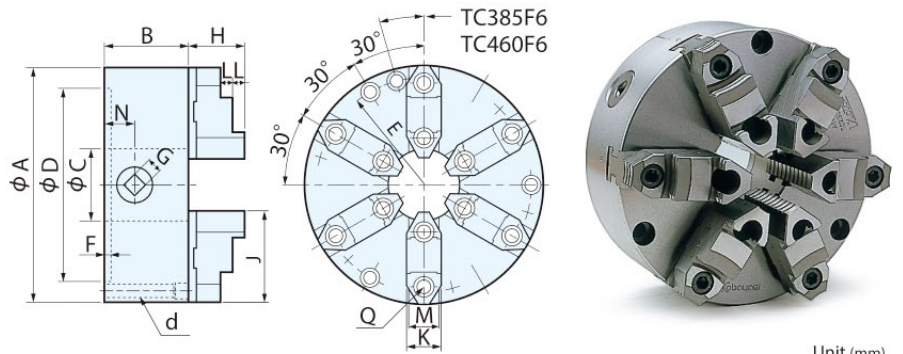

MODEL	No	A	B	C	D	E	F	H	J	K	L	M	N	G	Q	d
TC230F6	9	233	82	70 (75)	190 <sup>+0.029</sup> <sub>0</sub>	210	6	55	90	35	12	28	29.5	12	12-M12×25	3-M12×90
TC273F6	10	274	86	90 (100)	230 <sup>+0.029</sup> <sub>0</sub>	250	6	53	95	35	12	28	30.0	12	12-M12×25	3-M12×95
TC310F6	12	310	92	110 (120)	260 <sup>+0.032</sup> <sub>0</sub>	285	7	59	110	40	14	30	32.2	14	12-M12×30	3-M12×100
TC385F6	15	385	100	130 (150)	330 <sup>+0.036</sup> <sub>0</sub>	355	7	71	127	43	15	35	32.8	15	12-M16×35	6-M12×110
TC460F6	18	460	114	150 (190)	400 <sup>+0.036</sup> <sub>0</sub>	425	8	80	130	50	17	45	38.0	17	12-M20×45	6-M16×125

Dimension C in brackets( ) are Max. thru-hole diameter which can be machined.

MODEL	Max. Wrench Torque N · m (kgf · m)	Max. Static Gripping Force kN (kgf)	Gripping Range		Soft Jaw (6 pcs.)	Weight (kg)	GD <sup>2</sup> N · m <sup>2</sup> (kgf · m <sup>2</sup> )	Max. Speed min <sup>-1</sup> (r.p.m)
			Outside $\phi$ mm	Inside $\phi$ mm				
TC230F6	137.3 (14)	34 (3420)	25~190 (242)	95~169 (222)	SJ-100	23	6.87 (0.70)	1400
TC273F6	176.5 (18)	41 (4230)	25~229 (277)	110~208 (256)	SJ-100	31	12.9 (1.31)	1200
TC310F6	196.2 (20)	49 (5040)	32~258 (322)	140~238 (302)	SJ-115	43	22.8 (2.32)	1050
TC385F6	215.8 (22)	51 (5220)	32~329 (394)	150~302 (367)	SJ-135	70	57.3 (5.84)	850
TC460F6	255.0 (26)	59 (5980)	38~367 (478)	180~379 (490)	SJ-150	113	131 (13.4)	750

Values in ( ) are maximum values which the chucks can grip, but this is not recommended.

For master jaw dimensions and use of soft jaw, refer to page 18-19.

## 2-PIECE JAWS/FOR DIRECT MOUNTING TYPE

- 2-piece tongue and groove jaws
- One set of soft jaws and hard top jaws are included
- For direct mounting on Type A1 spindle noses
- Cast iron body



JIS.ASA-A

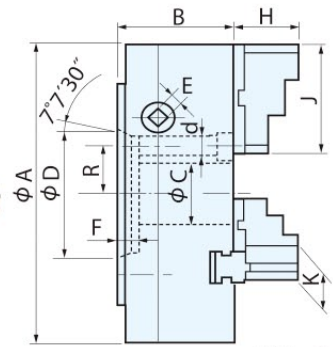

Unit (mm)

Chuck Size (MODEL)	Spindle Nose	No.	A	B	C	D	E	F	H	J	K	R	d	Weight (kg)
6 (TA5F165)	A1-5	340611	165	70	40	82.558	10	14.29	44	68	30	31.0	3-M10×60	10
8 (TA5F200)		340811	210	82	40		11	47	80	30	3-M10×75		19	
8 (TA6F200)	A1-6	340812	210	82	56	106.370	11	15.88	47	80	30	41.3	3-M12×70	18
9 (TA6F230)		340912	230	88	58		12		55	90	35		3-M12×75	23
10 (TA6F250)	A1 · A2-6	341012	255	92	58	139.714	12	17.46	53	95	35	55.6	3-M12×80	30
12 (TA6F310)		341212	310	105	78		14		60	110	40		6-M12×110	48
10 (TA8F250)	A1-8	341013	255	92	78	196.864	12	19.05	53	95	35	82.6	3-M16×80	29
12 (TA8F310)		341213	310	105	78		14		60	110	40		3-M16×95	48
15 (TA8F385)	A1 · A2-8	341513	385	111	100	196.864	15	19.05	71	127	43	85.7	6-M16×120	78
18 (TA8F460)		341813	460	129	110		17		80	130	50		6-M16×135	136
15 (TA11F385)	A1-11	341514	385	111	120	196.864	15	19.05	71	127	43	82.6	3-M20×100	77
18 (TA11F460)		341814	460	129	120		17		80	130	50		6-M20×120	132

※ Gripping range, gripping force, maximum rotation speed, and applicable soft jaws are the same as 3-JAW SELF-CENTERING CHUCKS NST. Also, refer to page 8. For use of soft jaw, refer to page 18-19.

## SELF-CENTERING CHUCKS

### TC-2F TYPE

- 2-jaw self-centering chuck
- 2-piece tongue and groove jaws
- One set of soft jaws and hard top jaws are included
- For adaptor mounting (Front-side mounting)
- Suitable for gripping irregular shaped works, such as a valve



## Scroll Chuck-Installed Plates for NST, TC, SC, series

### PLATES

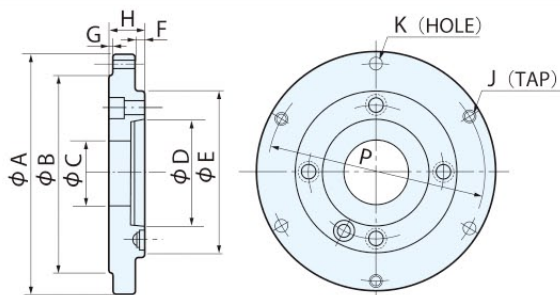

Unit (mm)

	7 A 6	9 A 6	10 A 6	12 A 6	15 A 6	10 A 8	12 A 8	15 A 8	12 A 11	15 A 11	18 A 11
A	195	235	277	313	388	277	313	388	313	388	463
B	156	191	231	261	331	231	261	331	261	331	401
C			60				84		110		136
D			106.375				139.719			196.869	
E			166				212			282	
F	12	10	9	8	4	14	13	9	—	18	15
G	3	3.5	3.5	4	4	3.5	4	4	5	4	5
H			40				45			54	
P	172	210	250	285	355	250	285	355	285	355	425
J	3-M10	3-M12	3-M12	3-M12	6-M12	3-M12	3-M12	3-M12	3-M12	3-M12	3-M16
K	3-φ11	3-φ13	3-φ13	3-φ13	—	3-φ13	3-φ13	—	3-φ13	—	—
Weight(kg)	8	11	15	19	35	17	22	33	26	40	56

※ B dimensions include a machining allowance of 1m/m. After installation of a plate to the lathe spindle nose, finish the outer circumferential face.

310 : HEAVY DUTY  
320 : MEDIUM DUTY  
311,321 : TOP JAW UNC TYPE

## FORGED STEEL BODY

- Heavy / Medium duty
- Directly installed (JIS/ASA) short tapered type
- Standard 2-piece tongue and groove jaws
- One set of hard top jaws included  
(Soft jaws not included)

SELF-CENTERING CHUCK

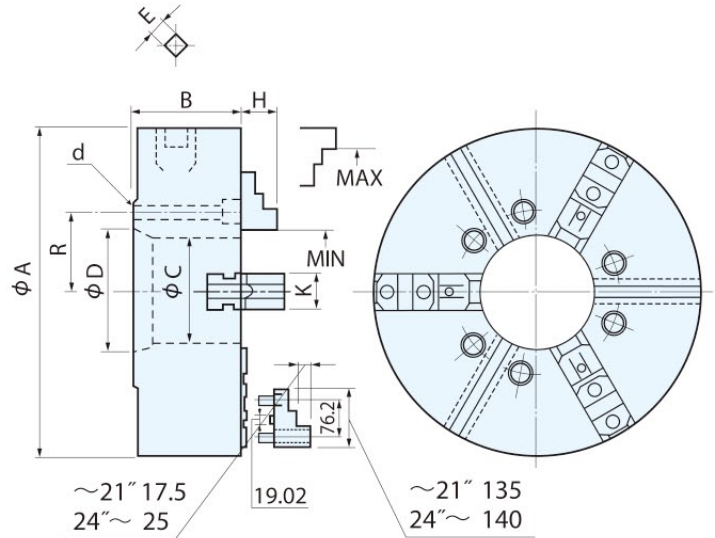
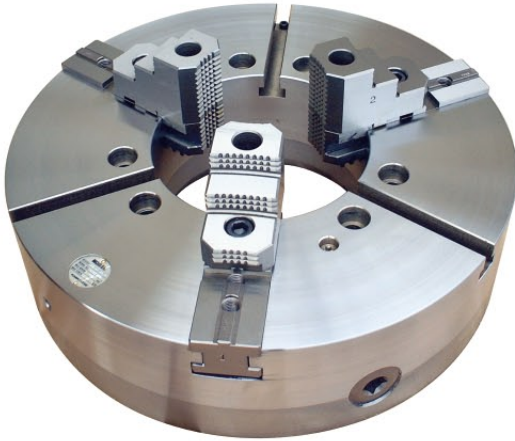

※1 : Dimensions   : metric,   : inch.    ※2 : Dimensions in brackets ( ) are Max. thru-hole diameter which can be machined.  
 ※3 : Bolt   : for 310, 320 model    Bolt   : for 311, 321 model

MODEL	Spindle Nose	A		B		C ※2	D		Gripping Range				R		
		(mm)	(inch)	(mm)	(inch)		(mm)	(inch)	(mm)	(inch)	MIN (mm)	MAX (mm)	(inch)	(inch)	
320-18-A8	A1 · A2- 8	457	18	140	5.51	115 (130)	4.53 (5.12)	139.7	5.5	65	2.6	430	16.9	85.7	3.37
310-18-A11	A1 · A2- 11	457	18	152	5.98	152 (160)	5.98 (6.3)	196.9	7.8	65	2.6	430	16.9	117.5	4.63
310-21-A11	A1 · A2- 11	535	21	152	5.98	152 (160)	5.98 (6.3)	196.9	7.8	80	3.1	490	19.3	117.5	4.63
310-21-A15	A1-15	535	21	152	5.98	204	8.03	285.8	11.3	90	3.5	490	19.3	123.8	4.87
310-24-A11	A1 · A2- 11	610	24	167	6.57	172 (185)	6.77 (7.28)	196.9	7.8	80	3.1	560	22	117.5	4.63
310-24-A15	A1 · A2- 15	610	24	167	6.57	241 (259)	9.49 (10.2)	285.8	11.3	90	3.5	560	22	165.1	6.5
310-24-A20	A1-20	610	24	167	6.57	266 (280)	10.47 (11.02)	412.8	16.3	90	3.5	560	22	184.2	7.25
310-28-A11	A1 · A2- 11	710	28	180	7.09	172 (185)	6.77 (7.28)	196.9	7.8	90	3.5	660	26	117.5	4.63
310-28-A15	A1 · A2- 15	710	28	180	7.09	241 (259)	9.49 (10.2)	285.8	11.3	110	4.3	660	26	165.1	6.5
310-28-A20	A1-20	710	28	180	7.09	318	12.52	412.8	16.3	150	5.9	660	26	184.2	7.25
310-32-A11	A1 · A2- 11	812	32	190	7.48	172 (185)	6.77 (7.28)	196.9	7.8	100	3.9	760	29.9	117.5	4.63
310-32-A15	A1 · A2- 15	812	32	190	7.48	266 (275)	10.47 (10.83)	285.8	11.3	150	5.9	760	29.9	165.1	6.5
310-32-A20	A1 · A2- 20	812	32	190	7.48	318 (370)	12.52 (14.57)	412.8	16.3	200	7.9	760	29.9	231.8	9.13
310-36-A15	A1 · A2- 15	915	36	200	7.87	266 (275)	10.47 (10.83)	285.8	11.3	150	5.9	860	33.9	165.1	6.5
310-36-A20	A1 · A2- 20	915	36	200	7.87	318 (370)	12.52 (14.57)	412.8	16.3	200	7.9	860	33.9	231.8	9.13

MODEL	Weight		Bolt For Top Jaw ※3		H		K		E	Gripping Force kN (kgf)	Max. Speed min <sup>-1</sup> (r.p.m)	d	
	(kg)	(lb)			(mm)	(inch)	(mm)	(inch)	(mm)				(inch)
320-18-A8	145	320	M20	UNC3/4	75	2.95	50	1.97	19	0.75	63 (6400)	1250	6-M16
310-18-A11	170	376	M20	UNC3/4	75	2.95	60	2.36	19	0.75	68 (6900)	1200	6-M20
310-21-A11	220	486	M20	UNC3/4	75	2.95	60	2.36	19	0.75	73 (7400)	1000	6-M20
310-21-A15	210	464	M20	UNC3/4	75	2.95	60	2.36	19	0.75	73 (7400)	1000	6-M22
310-24-A11	325	718	M20	UNC3/4	92	3.62	75	2.95	22	0.87	80 (8200)	900	6-M20
310-24-A15	300	663	M20	UNC3/4	92	3.62	75	2.95	22	0.87	80 (8200)	900	6-M22
310-24-A20	280	619	M20	UNC3/4	92	3.62	75	2.95	22	0.87	80 (8200)	900	6-M24
310-28-A11	465	1028	M22	UNC7/8	92	3.62	75	2.95	22	0.87	83 (8500)	650	6-M20
310-28-A15	440	972	M22	UNC7/8	92	3.62	75	2.95	22	0.87	83 (8500)	650	6-M22
310-28-A20	410	906	M22	UNC7/8	92	3.62	75	2.95	22	0.87	83 (8500)	650	6-M24
310-32-A11	645	1425	M22	UNC7/8	92	3.62	75	2.95	22	0.87	85 (8700)	550	6-M20
310-32-A15	600	1326	M22	UNC7/8	92	3.62	75	2.95	22	0.87	85 (8700)	550	6-M22
310-32-A20	585	1293	M22	UNC7/8	92	3.62	75	2.95	22	0.87	85 (8700)	550	6-M24
310-36-A15	850	1879	M22	UNC7/8	92	3.62	75	2.95	22	0.87	85 (8700)	450	6-M22
310-36-A20	810	1790	M22	UNC7/8	92	3.62	75	2.95	22	0.87	85 (8700)	450	6-M24

※For master jaw dimensions and use of soft jaw, refer to page 19.    ※Manufacture of chucks in sizes other than the above is available.

## 3-JAW SELF-CENTERING CHUCKS WITH COVER

- ~  $\phi 710$  : Steel body,  $\phi 800 \sim$  : Cast iron body
- With chip covers
- One set of hard top jaws are included  
(Soft jaws not included)

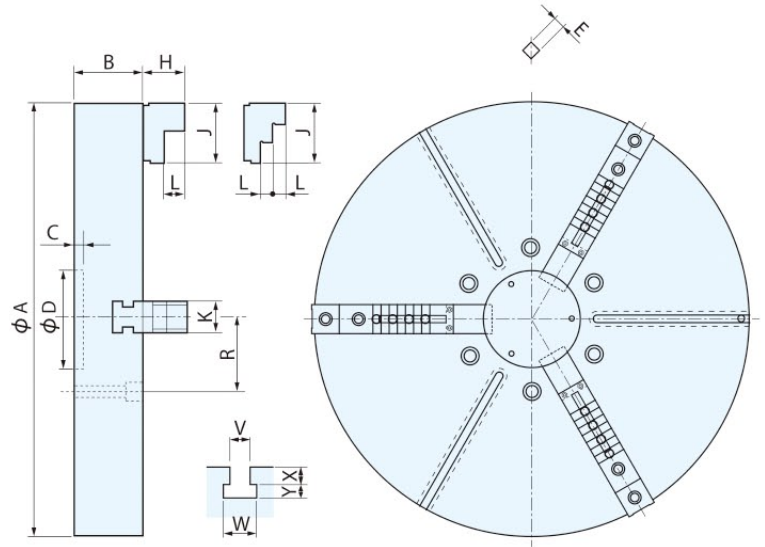
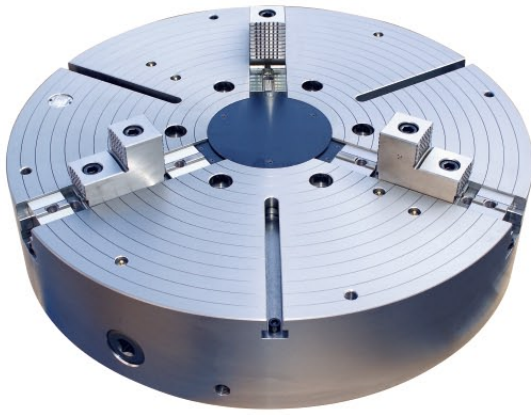

SELF-CENTERING CHUCK

Unit (mm)

MODEL	A	B	C	D(H7)	E	H	J	K	L	R	d	Jaw Type	V	W	X	Y
<b>SRK 535ST</b>	535	140	20	200	19	75	135	50	17.5	117.5	6-M20	3-Step	16	27	16	11
<b>SRK 610ST</b>	610	167	20	200	22	75	135	60	17.5	117.5	6-M20	3-Step	20	34	20	14
<b>SRK 710ST</b>	710	167	20	200	22	75	135	60	17.5	117.5	6-M20	3-Step	20	34	20	14
<b>SRK 800ST</b>	800	190	20	200	22	92	140	69	46	165.1	6-M24	2-Step	20	34	20	14
<b>SRK 915ST</b>	915	200	20	200	25.4	92	140	69	46	165.1	6-M24	2-Step	24	42	24	18
<b>SRK 1000ST</b>	1000	200	20	200	25.4	92	140	69	46	165.1	6-M24	2-Step	24	42	24	18
<b>SRK 1250ST</b>	1250	220	25	400	25.4	100	170	79	50	231.8	6-M24	2-Step	24	42	24	18
<b>SRK 1400ST</b>	1400	230	25	400	25.4	100	170	79	50	231.8	6-M24	2-Step	24	42	24	18
<b>SRK 1500ST</b>	1500	240	25	500	25.4	100	170	79	50	290	9-M24	2-Step	24	42	24	18
<b>SRK 1600ST</b>	1600	240	25	500	25.4	100	170	79	50	290	9-M24	2-Step	24	42	24	18
<b>SRK 1800ST</b>	1800	250	25	500	25.4	100	170	79	50	290	9-M24	2-Step	24	42	24	18

MODEL	Max. Static Gripping Force kN (kgf)	Max. Wrench Torque N · m (kgf · m)	Gripping Range		Max. Speed min <sup>-1</sup>	Chuck Weight (kg)	Soft Jaw	Bolt For Top Jaw
			Outside ( $\phi$ mm) MIN ~ MAX	Inside ( $\phi$ mm) MIN ~ MAX				
<b>SRK 535ST</b>	72 (7300)	372 (38)	160 ~ 475	270 ~ 490	950	195	SJ-150	M20
<b>SRK 610ST</b>	73 (7500)	392 (40)	215 ~ 535	330 ~ 550	800	310	SJ-155	M20
<b>SRK 710ST</b>	73 (7500)	392 (40)	220 ~ 615	330 ~ 630	650	460	SJ-155	M20
<b>SRK 800ST</b>	73 (7500)	490 (50)	250 ~ 685	390 ~ 650	560	600	SJ-160	M20
<b>SRK 915ST</b>	78 (8000)	490 (50)	275 ~ 825	420 ~ 790	500	800	SJ-160	M20
<b>SRK 1000ST</b>	78 (8000)	490 (50)	275 ~ 880	420 ~ 850	470	900	SJ-160	M20
<b>SRK 1250ST</b>	68 (7000)	490 (50)	310 ~ 1120	465 ~ 1090	350	1500	SJ-170	M22
<b>SRK 1400ST</b>	68 (7000)	490 (50)	310 ~ 1270	465 ~ 1240	300	1750	SJ-170	M22
<b>SRK 1500ST</b>	68 (7000)	588 (60)	320 ~ 1370	475 ~ 1340	260	2150	SJ-170	M22
<b>SRK 1600ST</b>	68 (7000)	588 (60)	320 ~ 1470	475 ~ 1440	230	2600	SJ-170	M22
<b>SRK 1800ST</b>	68 (7000)	588 (60)	410 ~ 1675	560 ~ 1640	200	3300	SJ-170	M22

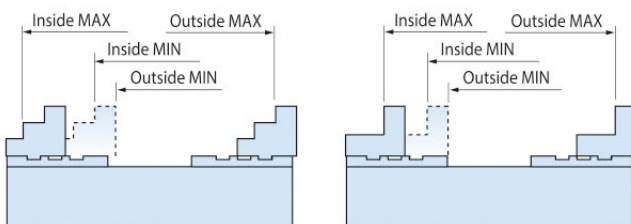

SELF-CENTERING CHUCK

## LOW PROFILE LIGHT WEIGHT TYPE

- Chucks used being installed on a tombstone, machining center table, or 5-axis machine table (Note ※1)
- This will not influence the maximum load capacity and height of the workpiece since it is designed to be lightweight and thin-shaped
- With chip covers

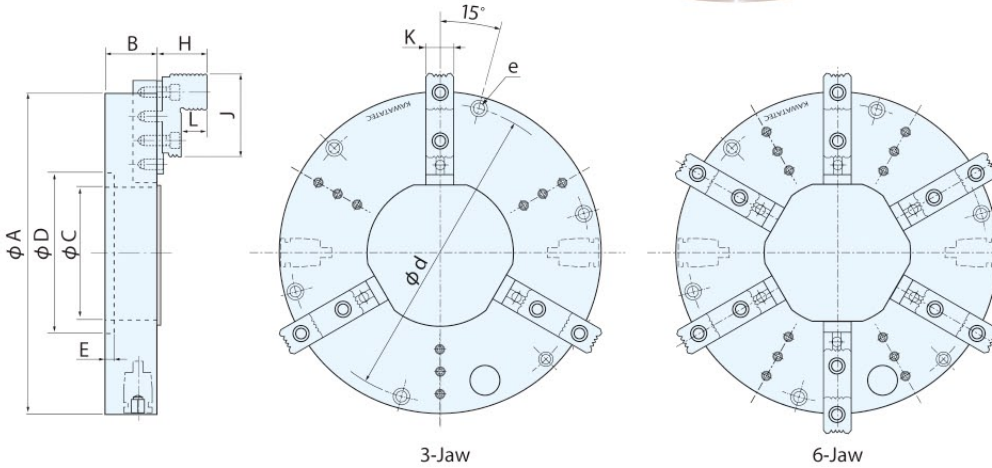
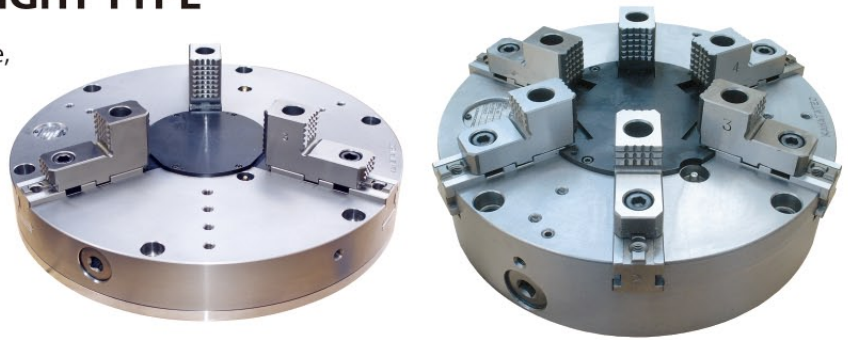

MODEL	A	B	C	D(H7)	E	K	H	J	L	d	e (divided equally)	Gripping Force kN	Gripping Range mm
TM300	300	75	125	130	14	30	43	80	20	275	4-M12	49	$\phi 80 \sim \phi 260$
TM400	400	85	180	185	15	35	58	110	28	375	6-M12	59	$\phi 95 \sim \phi 350$
TM500	500	80	146	150	14	44	78	130	40	465	6-M16	73	$\phi 135 \sim \phi 450$
TM600	600	85	210	215	19	44	78	130	40	565	6-M16	73	$\phi 220 \sim \phi 540$
TM800	800	120	295	300	22.5	69	105	140	46	760	6-M20	83	$\phi 310 \sim \phi 725$
TM1000	1000	125	410	420	25	69	105	140	46	960	6-M20	83	$\phi 430 \sim \phi 920$

MODEL	Max. Wrench Torque	Max. Speed min <sup>-1</sup>	Weight kg	Optional	
				Soft Jaw	Ratchet Handle / Socket
TM300	196	1800 (1600)	28 (30)	SJ- 85	RT12.7D / SK12D12.7B
TM400	245	1450 (1250)	60 (65)	SJ-115	RT12.7D / SK14D12.7B
TM500	294	1150 (900)	100 (110)	SJ-135	RT19D / SK15D19B
TM600	294	950 (750)	155 (160)	SJ-135	RT19D / SK15D19B
TM800	392	600 (450)	400 (410)	SJ-160	RT19D / SK19D19B
TM1000	392	450 (380)	610 (620)	SJ-160	RT19D / SK19D19B

( ) : 6-JAW

**CAUTION**

Note ※1

This chuck is designed on the assumption that it is installed on a tombstone and table with sufficient rigidity. Accordingly, it cannot be used being directly installed on the spindle of a lathe.

## Installation Example

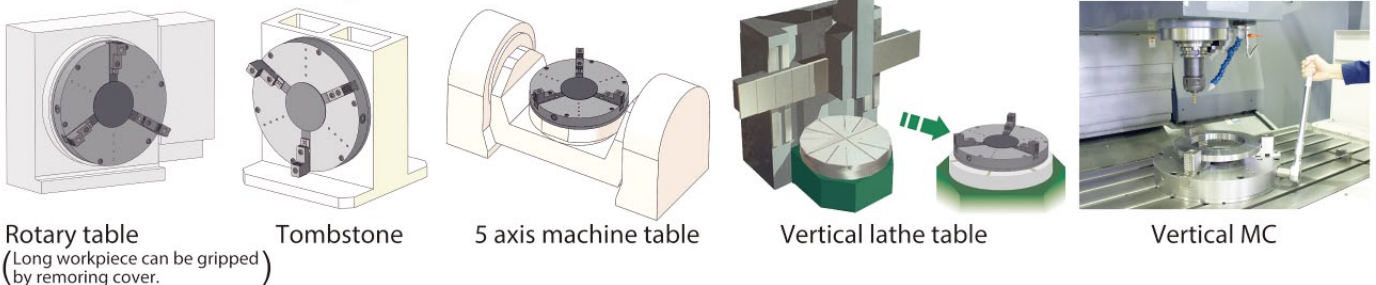

Rotary table  
(Long workpiece can be gripped by removing cover.)

Tombstone

5 axis machine table

Vertical lathe table

Vertical MC



## WITH LARGE THRU HOLE FOR PIPE MACHINING

- Solid jaw type and 2-piece jaws type are available
- Cast iron body
- Clamping with 5 jaws prevents pipes from deformation



SOLID JAW TYPE

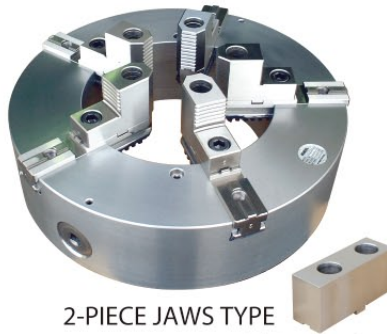

2-PIECE JAWS TYPE

Soft jaws (5pcs.) included

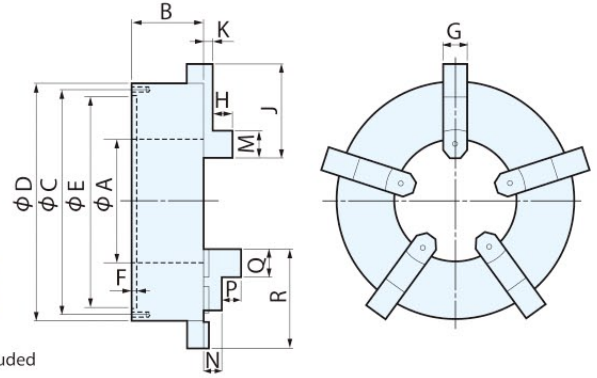

Unit (mm)

MODEL	A	B	C	D	E (H7)	F	G	H	J	K	M	N	P	Q	R
<b>PH 175</b>	175	109	330	350	300	7	35	30	130	10	40	-	-	-	-
<b>PH 260</b>	260	150	472.5	500	445	10	50	40	200	20	55	-	-	-	-
<b>PH 320</b>	320	150	530	560	505	10	50	50	230	20	70	-	-	-	-
<b>PH 420</b>	420	170	665	700	640	15	60	50	260	30	80	-	-	-	-
<b>PH 175-2P</b>	175	109	330	350	300	7	35	-	-	-	-	35	20	45	125
<b>PH 260-2P</b>	260	150	472.5	500	445	10	50	-	-	-	-	38	40	60	210
<b>PH 320-2P</b>	320	150	530	560	505	10	50	-	-	-	-	40	48	70	220
<b>PH 420-2P</b>	420	170	665	700	640	15	60	-	-	-	-	65	40	55	260

MODEL	Mounting Bolt	Max. Wrench Torque N · m(kgf · m)	Max. Static Gripping Force kN(kgf)	Max. Speed min <sup>-1</sup> (r.p.m)	Weight kg	Soft Jaw
<b>PH 175</b>	6-M12	392(40)	34.3(3500)	1200	45	-
<b>PH 260</b>	6-M12	392(40)	30(3060)	850	100	-
<b>PH 320</b>	6-M12	392(40)	29(2960)	750	140	-
<b>PH 420</b>	8-M12	490(50)	32(3265)	550	350	-
<b>PH 175-2P</b>	6-M12	392(40)	34.3(3500)	1200	45	SJ-115
<b>PH 260-2P</b>	6-M12	392(40)	30(3060)	850	100	SJ-135
<b>PH 320-2P</b>	6-M12	392(40)	29(2960)	750	140	SJ-150
<b>PH 420-2P</b>	8-M12	490(50)	32(3265)	550	350	SJ-155

		Gripping Range				
SOLID JAW TYPE		2-PIECE JAWS TYPE				
	Outside (φ mm)	Inside (φ mm)	Outside (φ mm)	Inside (φ mm)		
MODEL	A1	B1	MODEL	A2	A3	B2
<b>PH 175</b>	40~170	125~250	<b>PH 175-2P</b>	40~170	180~322	140~260
<b>PH 260</b>	50~255	175~375	<b>PH 260-2P</b>	50~412	202~564	180~530
<b>PH 320</b>	60~315	200~455	<b>PH 320-2P</b>	60~465	195~605	210~605
<b>PH 420</b>	150~415	310~575	<b>PH 420-2P</b>	140~520	322~700	260~700

Accessories : Handle, Mounting Bolts, L-Wrench, Eye Bolt.  
 Specially manufactured chucks with an A dimension of φ 1200 are available.

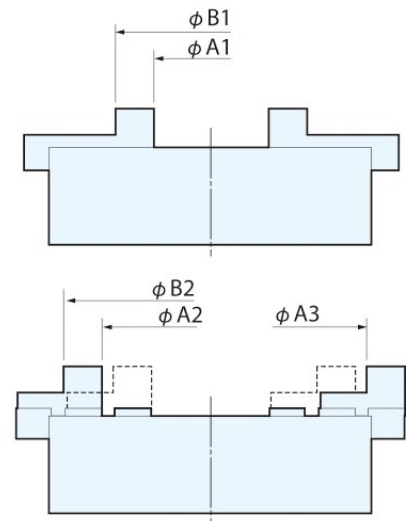

SELF-CENTERING CHUCK

# Lathe Spindle Nose and Chuck Installation

THE MOST COMMON TYPES OF SPINDLE NOSES

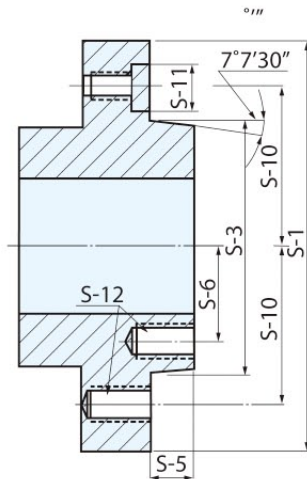

These spindle noses are used on turret lathes, single spindle automatic lathes and big engine lathes.

- A-1** Has tapped holes on both the outer bolt circle S-10 and inner bolt circle S-6
- A-2** Has tapped holes on the outer bolt circle S-10, but has no holes on inner bolt circle S-6.

PARTS

Spindle Nose							Unit (mm)	
	S-1	S-3	S-5	S-6	S-10	S-11	S-12	
							MM	UNC
<b>A-5</b>	133	82.563 (+0.01)	14.288 (-0.025)	30.95	52.4	15.88 (+0.027)	M 10	7/16"-14"
<b>A-6</b>	165	106.375 (+0.01)	15.875 (-0.025)	41.30	66.7	19.05 (+0.033)	M 12	1/2"-13"
<b>A-8</b>	210	139.719 (+0.012)	17.462 (-0.025)	55.55	85.7	23.81 (+0.033)	M 16	5/8"-11"
<b>A-11</b>	280	196.869 (+0.014)	19.050 (-0.025)	82.55	117.5	28.58 (+0.033)	M 20	3/4"-10"
<b>A-15</b>	380	285.775 (+0.016)	20.638 (-0.025)	123.80	165.1	34.93 (+0.039)	M 22	7/8"- 9"
<b>A-20</b>	520	412.775 (+0.02)	22.225 (-0.025)	184.15	231.8	41.28 (+0.039)	M 24	1"- 8"
<b>A-28</b>	725	584.225 (+0.023)	25.400 (-0.025)	265.10	323.8	50.80 (+0.046)	M 30	1 1/4"- 7"

## Rear/ Front-Side Mounting For NST, TC, SC series

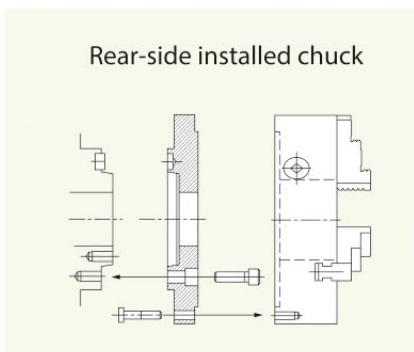

For rear-side installed type chucks, insert hexagon bolts in the tapped holes on the main body bottom part from the backside of the plate and fix the chuck.

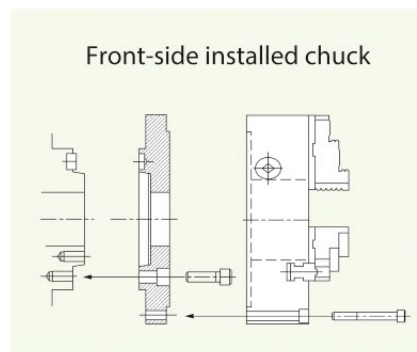

For front-side installed chucks, insert hexagon socket bolts in the tapped holes from the front side of the main body and fix the chuck.

### Cautions for installation

When installing the chuck to the lathe, inspect that no flaws, rust, nor attached matter exists on each of the contact surfaces of the spindle, plate, and chuck, and remove any of these conditions. Please carry out maintenance consistently, since a small flaw, etc., will largely influence the degree of accuracy.

# PART NAME and DIMENSION

SPARE PARTS

## FOR INDEPENDENT CHUCKS

## FOR SELF-CENTERING CHUCKS



TOP JAW



MASTER JAW



TOP JAW



MASTER JAW



OPERATING SCREW



STOPPER



PINION



PINION RETAINER



HANDLE



JAW



SCROLL GEAR



HANDLE

# Order and Repair of Part

### SOLID JAWS

**SERIES44**  
**SERIES46**

Fitting jaw to main body  
jaw way section

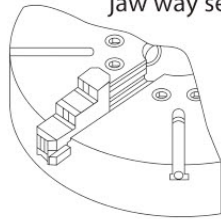

Grind the jaw way section, and carry out fitting the jaw to the chuck main body jaw way section.

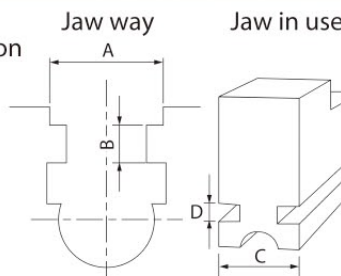

Grind the jaw in accordance with the dimensions A to D.

Jaw in use

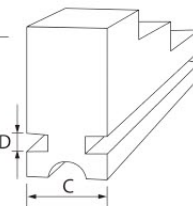

<Caution>

Jaws are stored in a mill scale condition in our stock. When placing an order or requesting repair of a jaw, send the jaw with the chuck main body. We will manufacture or repair the jaw while fitting it to the chuck main body. However, if you cannot send the chuck main body, measure the dimensions A, B, C and D in the above figure before an order or request.

### TOP JAWS and MASTER JAWS

**SERIES31**  
**SERIES32**  
**SERIES NST, TC,TA**

Fitting jaw to main body  
jaw way section

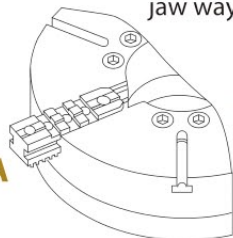

Grind the jaw way section, and carry out fitting the master jaw to the chuck main body jaw way section.

Spin finishing

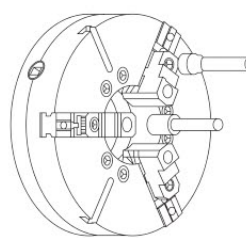

When the master jaw or top jaw of the chuck is replaced, make sure to attach it to the chuck used before spin finishing and step finishing.

<Caution>

When placing an order of parts for the top jaw or master jaw, the degree of accuracy cannot be maintained unless spin finishing and step finishing are carried out as shown in the figure on the left.

# PART NAME and DIMENSION

SPARE PARTS

## OPERATING SCREW

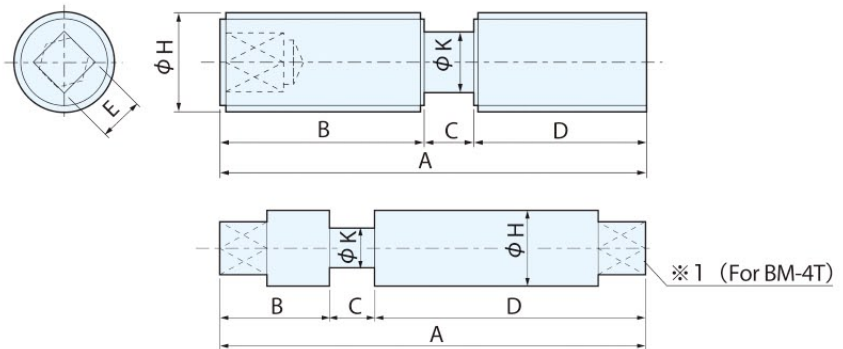

## OPERATING SCREW DIMENSION

No.	Chuck Size	Chuck No.	A	B	C	D	H (φ)	K (φ)	E	Unit (mm)
OP120036	300	441240(FC)	114	76	14	24	29.8	15	12	
OP120024		441212(A6)/4612FC/4612A6	112	41	14	57	29.8	15	12	
OP120037	350	441440(FC)	134	91	14	29	29.8	15	12	
OP120025		441412(A6)	134	66	14	54	29.8	15	12	
OP120018		441413(A8)/ 4614FC/4614A6/ 4614A8	123	46	14	63	29.8	15	12	
OP120038	400	441640(FC)	152	104	18	30	34	18	14	
OP120026		441612(A6)	152	84	18	50	34	18	14	
OP120019		441613(A8)/4616FC/4616A6, 4616A8	147	49	18	80	34	18	14	
OP120039	450	441840(FC)	172	119	18	35	34	18	14	
OP120020		441812(A6)/441813(A8)	172	82	18	72	34	18	14	
OP120007		441814(A11)/4618FC/4618A8/4618A11/IDV450ST	158	54	18	86	34	18	14	
OP120040	500	442040(FC)	192	134	18	40	34	18	14	
OP120028		442012(A6)	202	109	18	75	34	18	14	
OP120021		442013(A8)	192	109	18	65	34	18	14	
OP120009		442014(A11)/4620FC/4620A8/4620A11/IDV500ST	184	77	18	89	34	18	14	
OP900010	535	410-21-A15	160	40	25	95	45	25	19	
OP120041	550	442240(FC)	214	154	18	42	34	18	14	
OP120012		442213(A8)/442214(A11)	208	82	18	108	34	18	14	
OP120042	600	442440(FC)	230	163	20	47	36	19	15	
OP120023		442413(A8)	230	153	20	57	36	19	15	
OP120014		442414/4624FC/4624A8/4624A11/IDV600ST	230	123	20	87	36	19	15	
OP900013	610	410-24-A15	180	50	25	105	50	30	22	
OP900014		410-24-A20	140	50	25	65	50	30	22	
OP120043	650	442640(FC)	260	177	20	63	36	19	15	
OP120016		442614(A11)	257	127	20	110	36	19	15	
OP123006	700	442813(A8)/442814(A11)/4628FC/IDK(V)700ST	274	100	24	150	40	22	16	
OP123009	750	443013(A8)/443014(A11)/4630FC	300	180	24	96	40	22	16	
OP123023	800	MC800	314	118	24	172	40	22	16	
OP123049		443215(A15)	264	135	25	105	50	30	26	
OP123532	800/915/1000	IDK(V)800/915/1000ST	310	55	25	230	45	25	19	
OP123012	810	443214(A11)/4632FC	309	177	25	107	50	30	26	
OP900024		410-32-A15	266	90	25	151	50	30	22	
OP900026		410-32-A20	240	90	25	125	50	30	22	
OP123015	915	443614(A11)	371	222	25	124	50	30	26	
OP123025	1000	MC1000	404	150	24	230	40	22	16	
OP123016		444014(A11)	404	149	25	230	50	30	26	
OP123029		444015(A15)	364	225	25	115	50	30	26	
OP123042	1200	444714	490	179	25	286	50	30	26	
OP123686		444715	460	179	25	256	50	30	26	
OP123019	1400	445514(A11)/445515(A15)	560	212	25	323	50	30	26	
OP123044	1500	445914(A11)/445915(A15)	570	220	25	325	50	30	26	
OP123045	1600	446314(A11)/446315(A15)	570	243	25	303	50	30	26	
OP130008	-	BM-3T	176	43	20	113	36	19	15	
OP130009	-	BM-4T (Please see ※ 1)	225	58	24	143	40	22	22	

(E=26 : Hexagon)

# PART NAME and DIMENSION

SPARE PARTS

## 44 · 46SERIES STANDARD SOLID JAW

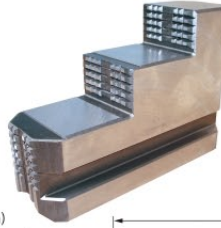

Unit (mm)

Chuck Size	A	B	C	D	E	J	K	L
<b>12·14</b>	76.5	12.5	12	36	35	112	35	18
<b>16·18</b>	90.5	14.5	14	43	37	132	40	22
<b>20</b>	102.5	15.5	15	49	44	150	45	27
<b>24</b>	109.5	16.5	16	53	47	160	50	28
<b>28·30</b>	136.5	18.5	18	65	50	190	55	32
<b>32·36·40</b>	150.5	20.5	20	65	60	200	60	35
<b>47·55·59·63·71</b>	170.5	25.5	25	75	65	230	80	40

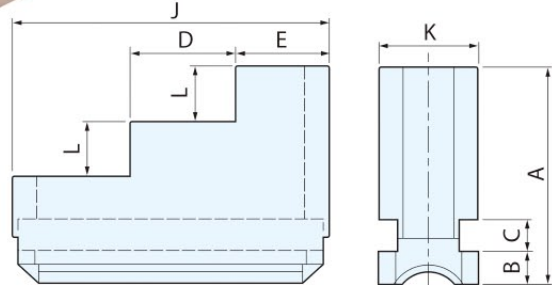

## 31 · 32 · 34 · 41 · 42 SERIES

AMERICAN STANDARD MASTER JAW DIMENSIONS  
(2-PIECE TONGUE & GROOVE)

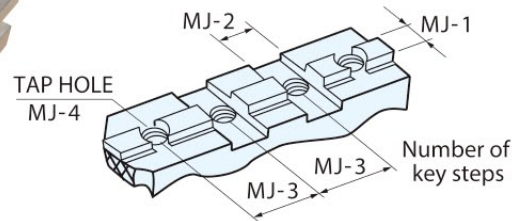
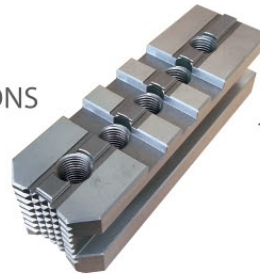

Unit (mm)

SERIES34	SERIES31·41	SERIES32·42	MJ-1	MJ-2	MJ-3	MJ-4	Number of key steps
6"			7.94	12.7	19.05	M10 UNC3/8 (16)	1
7"·8"			7.94	12.7	22.2	M10 " 3/8 (16)	1
9"·10"			12.7	19.02	27.0	M12 " 1/2 (13)	1
12"			12.7	19.02	31.75	M12 " 1/2 (13)	1
15"			12.7	19.02	38.1	M16 " 5/8 (11)	1
18"	18"	18"	12.7	19.02	38.1	M20 " 3/4 (10)	2
	21"·24"	21"~32"	12.7	19.02	38.1	M20 " 3/4 (10)	3
	28"~		12.7	19.02	38.1	M22 " 7/8 (9)	3 (Partially, 4)

## STANDARD HANDLE



**T-HANDLE**

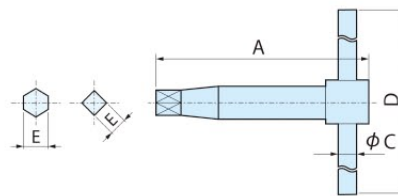

For Independent Chuck

Unit (mm)

E	A	C (φ)	D	Reference Chuck Size
□12	165	13	300	300 · 350
□14	220	16	450	400 · 450 · 500 · 550
□15	220	16	450	600 · 650
□16	250	19	500	700 · 750 · MC1000
□19	290	19	500	(41 · 42 SERIES) 21" · 28"(A-11) · 32"(A-11)
□22	320	22	700	(41 · 42 SERIES) 24"~42"
○26	90	22	700	1000~1800
○26	290	22	700	810 · 915 · 1000(A-11)
○26	330	22	700	800(A-15) · 1200~1600
○26	360	22	700	1800

For Self-Centering chuck

Unit (mm)

E	A	C (φ)	D	Reference Chuck Size
□14	220	16	450	PH175
□19	290	19	500	PH260 · PH310 · WPS (31 · 32 SERIES) 18" · 21"
□22	320	22	700	(31 · 32 SERIES) 14"~36"

For Victor chuck

Unit (mm)

E	A	C (φ)	D	Reference Chuck Size
□10	120	10	210	6" (H-165)
□11	140	11	240	7" (H-190)
□12	160	13	290	9" (H-230)
□12	160	13	330	10" (H-273)
□14	160	16	390	12" (H-310)
□15	175	16	450	15" (H-385)
□17	175	16	500	18" (H-460)

# NOBEL SOFT BLANK TOP JAWS



- S45C is used as a standard soft jaw material, and the jaw can also be used as a rigid jaw by high-frequency quenching after you machine the soft jaw.

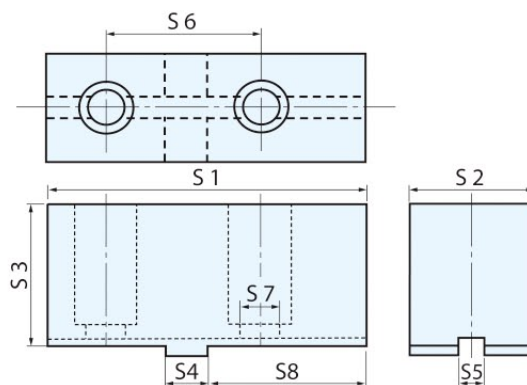

**SJ** type

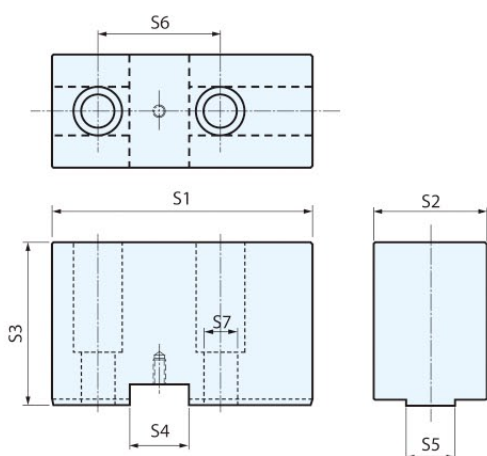

**SJV** type

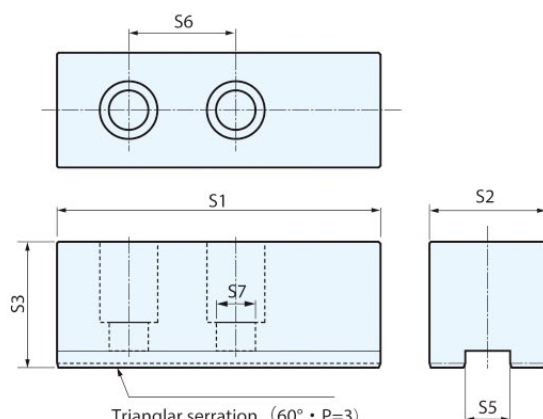

**SHJ** type

## ■ SJ TYPE

MODEL	Chuck Size Applicable Soft Jaws					S1	S2	S3		S4	S5	S6	S7	S8	Standard Jaw Weight Per One (kg)
	SELF-CENTERING CHUCK		INDEPENDENT CHUCK		Standard			Higher							
	34	31	32	41					42						
<b>SJ-62</b>	5"					62	23	32.5	—	12.7	7.94	32	9	27	0.4
<b>SJ-70</b>	6"					70	30	36	(60)	12.7	7.94	38.1	11	32	0.5
<b>SJ-85</b>	7" · 8"					85	30	38	(60)	12.7	7.94	44.4	11	41	0.6
<b>SJ-100</b>	9" · 10"					100	35	46	(85)	19.02	12.7	53.9	14	45	1
<b>SJ-115</b>	12"					115	40	49	(90)	19.02	12.7	63.5	14	53	1.5
<b>SJ-135</b>	15"					135	45	60	(120)	19.02	12.7	76.2	18	65	2.5
<b>SJ-150</b>	18"~24"		18" · 21"			150	49	70	(120)	19.02	12.7	76.2	22	73.98	3.5
<b>SJ-155</b>	18" · 21"		24"	18" · 21"	24"~32"	155	59	80	(140)	19.02	12.7	76.2	22	78.98	5
<b>SJ-160</b>	24"			24"		160	74 (69)	90	(150)	19.02	12.7	76.2	22	83.98	7
<b>SJ-170</b>	28"~36"			28"~42"		170	74	90	(150)	19.02	12.7	76.2	24	93.98	8

Jaw height (S3) includes two types of standard and higher jaws.

## ■ SJV TYPE, SHJ TYPE

MODEL	CVH	CV	4HA	FCH	ASM	S1	S2	S3	S4	S5	S6	S7	Weight Per One (kg)
<b>SJV-150</b>	700~800		610~810	700~800		150	69	86	38.9	28	70	22	6
<b>SJV-170</b>	1000~1600		1000~1600	1000~1600		170	74	106	38.9	32	80	22	9
<b>SHJ-18</b>		530			460~600	180	64	70	-	25	60	22	6
<b>SHJ-24</b>		610				210	74	90	-	25	80	22	10

**3-Jaw Self-Centering Chuck Soft Jaw Boring Rings**



- Do not require rings and cored bars which have been conventionally necessary for boring soft jaws, and greatly contributes significantly to cost reductions and labor savings.
- Minimizes wear of soft jaws since the operation is simple and stepless fine adjustment is enabled.
- Very convenient when conventional cored bars cannot be used to bore soft jaws for gripping small-diameter objects.
- Machining range is enlarged by reversing the installation direction of the jaw.
- Can be used for hydraulic chucks.

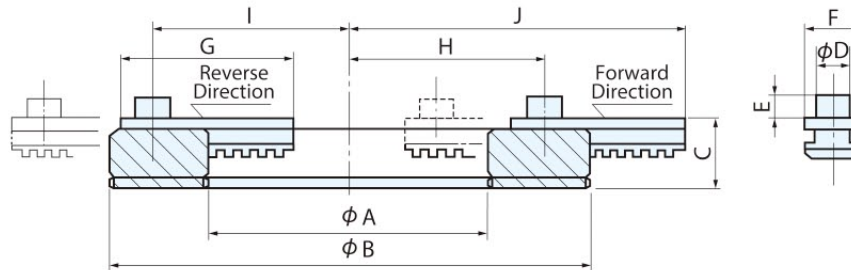

SPECIFICATION		MODEL	JL-063	JL-100	JL-125	JL-160	JL-200
Main Body Inner Diameter		$\phi A$	63	100	125	160	200
Main Body Outer Diameter		$\phi B$	132	170	200	248	300
Effective Thickness		C	26	26	26	31	31
Pin Diameter-Length		$\phi D$ -E	12-7	13-7	13-7	14-8.5	16-8.5
Jaw Width-Length		F-G	16-53	19-61	19-61	24-80	24-80
Pin( $\phi D$ ) Center	Forward Direction H	Outer Clamping	21~52	32~70	45~85	51~106	74~130
	Internal Clamping		14~45	25~63	37~77	42~97	65~121
Travel Range (Radius)	Reverse Direction I	Outer Clamping	52~83	70~108	83~123	105~160	128~184
	Internal Clamping		45~76	63~101	75~115	96~151	119~175
Jaw Max. Swing (Outer Clamping) J			95	120	135	173	197
Jaw Stroke (Scroll One Rotation)			7.3	7.3	7.3	8.5	8.5
Load Capability Per Jaw kN(kgf)			14 (1,400)	15 (1,500)	15 (1,500)	17 (1,750)	23 (2,300)
Max. Speed	$\text{min}^{-1}(\text{r.p.m})$		900	800	700	600	500
Weight	kg		1.8	2.5	3.1	5.4	7.4
Standard Applicable Chuck Size			#4~6	#5~8	#6~10	#8~12	#10~15

JAW

# NOBEL BORING MILL JAWS

SERIES BM

- Use for large-sized lathes, vertical lathes, boring lathes, milling machines, and jig installations.
- 4 pcs.(1 set)

## BM-3T

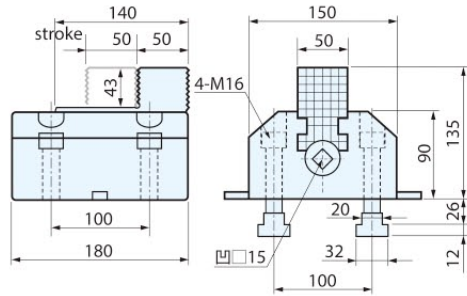

Accessory  
T-Handle

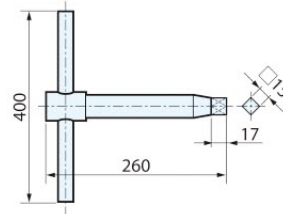

Gripping Force : 29kN  
(Input Torque) (392N·m)  
Weight : 19kg

## BM-4T

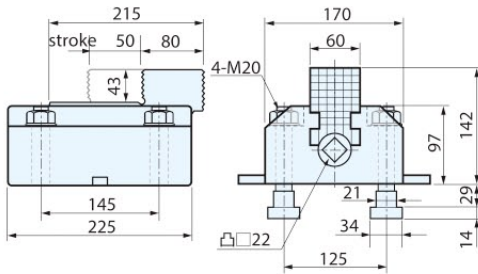

Accessory  
Ratchet handle (19D)  
Socket SK22B19B

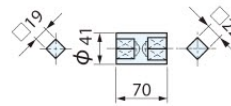

Gripping Force : 39kN  
(Input Torque) (441N·m)  
Weight : 26kg

## BM-4T-2P (2-Piece Jaws Type)

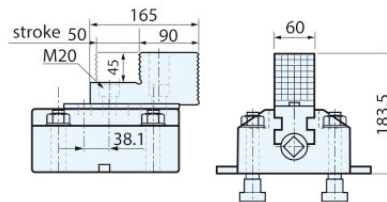

Soft Jaw : SJ-155  
(OPTION)



Gripping Force : 39kN  
(Input Torque) (441N·m)  
Weight : 28kg

## BM-7T

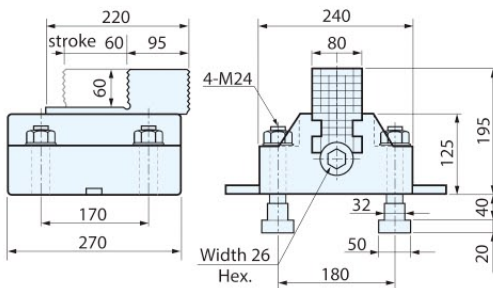

Accessory  
Ratchet handle (25.4D)  
Socket SK26D25.4B

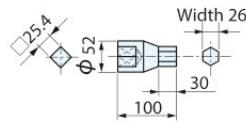

Gripping Force : 68kN  
(Input Torque) (735N·m)  
Weight : 55kg

## BM-6T

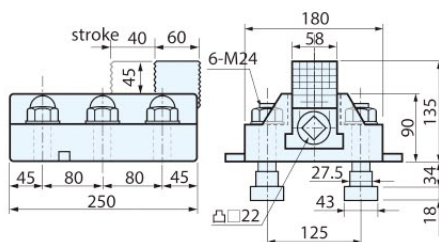

Accessory  
Ratchet handle (19D)  
Socket SK22B19D

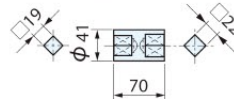

Gripping Force : 59kN  
(Input Torque) (686N·m)  
Weight : 30kg

JAW



# BORING MILL JAWS

## FACE PLATE AND BORING MILL JAWS

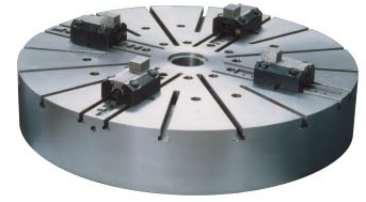
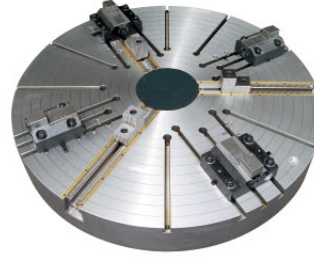
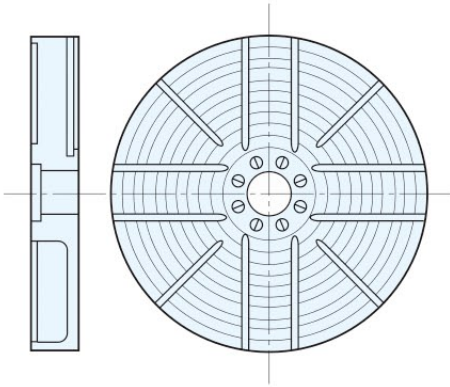

- Face plates are also manufactured.  $\phi$  800 ~  $\phi$  3,000
- We can design and manufacture boring mill jaws and face plates at your request. Please inform us of the chuck diameter, installation dimensions, size of workpiece and machining conditions, etc.

## POWERFUL TYPE BORING MILL JAWS 4 pcs. 1 set (with a retightening clamp)

### 30HT

Thrust force of one jaw MAX 15t  
(Reference dimensions)

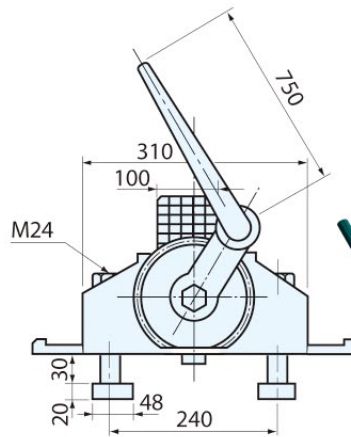
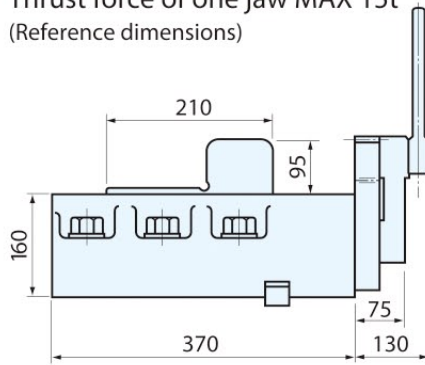

### 60HT

Thrust force of one jaw MAX 20t  
(Reference dimensions)

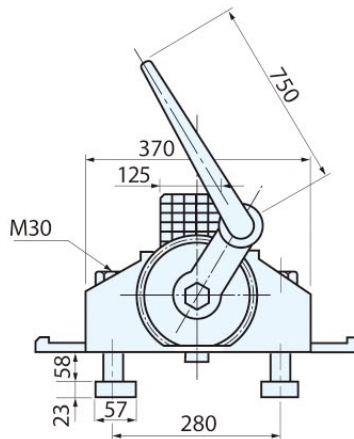
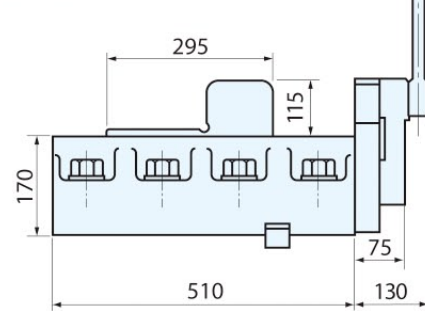

### SPECIAL DESIGN

### With JAKOB power clamp screw

(Reference dimensions)

Power Clamp Screw  
Thrust force of one jaw 15t~

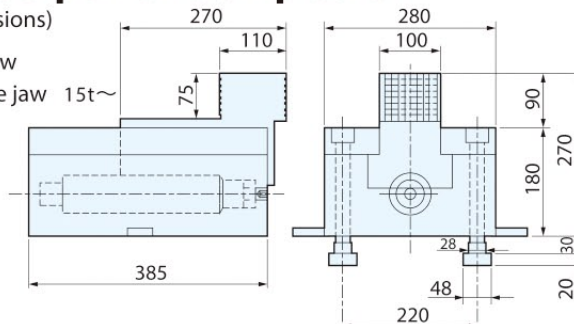

- Design and manufacture of special boring mill jaws are also available at your request.

# POWER WRENCHES AND POWER WRENCH CHUCKS

- This device is a system to tighten the pinions of scroll chucks not manually but automatically.
- This can be added to any of our scroll chucks as a special specification.

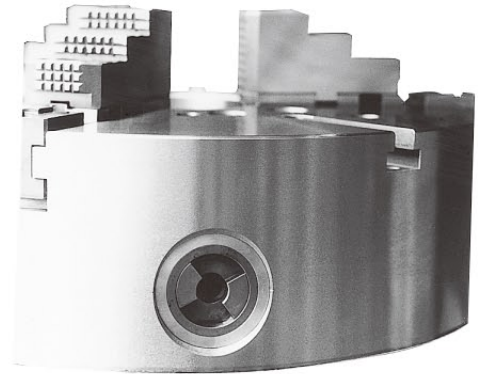

## METHODS OF OPERATION

- ① Moving forward while rotating the end of the power wrench
- ② The wrench interlocks with the chuck pinion and rotates the pinion
- ③ After the jaws move, the wrench moves backward
- ④ The chuck starts to rotate

- The power wrench is powered by four hydraulic circuits (wrench forward and backward, and wrench forward and reverse rotation)
- The wrench rotation is powered by a hydraulic motor  
※ Since the hydraulic source and software for the wrench movement are not included, they need to be prepared at your end
- It is perfect for using with a pallet changer, in systems where large through holes are required, and in specifications that include long jaw strokes, etc.

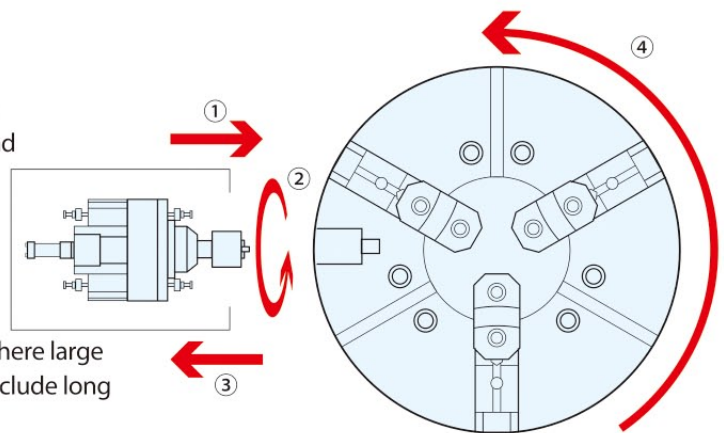

POWER WRENCH

## Cautions before use

Software for the hydraulic source and wrench operations are not included. Please prepare at your work site.

The following automatic operation conditions are required to be carried out.

- A : Spindle position stop ( $\pm 0.5\text{mm}$  on the outer circumference)
- B : Installation of limit SW for confirmation of chuck jaw retraction
- C : Hydraulic equipment for wrench operation
- D : Sequence circuit for control of the wrench  
(Please contact us for the reference flowchart.)

## CHUCK FOR POWER WRENCH OPERATION

- This chuck was designed to be moved by a power wrench.
- Our other scroll chucks can be converted to power wrench specifications.



## POWER WRENCH (PW-H24)

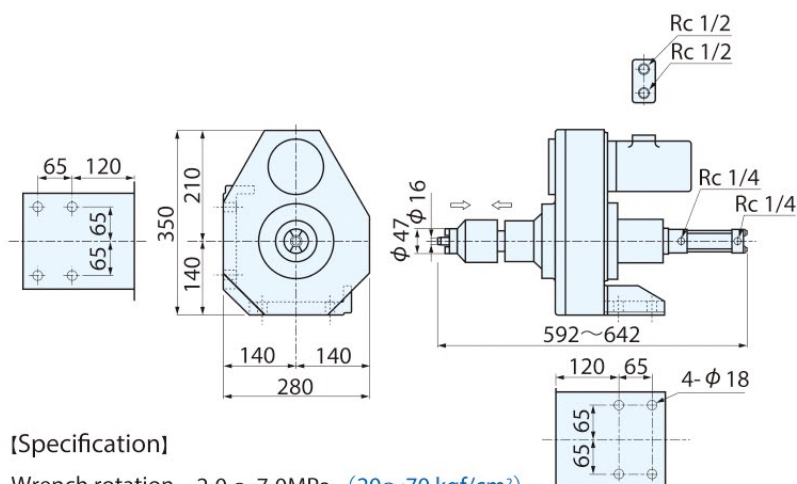
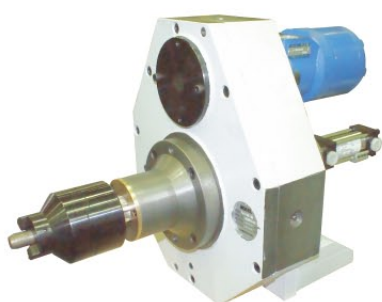

- Jaw thrust force for tightening is optional according to operating pressure.
- Jaw travel speed can be changed depending on the oil flow rate.
- The power wrench is compact, and can be installed from above, below or at the side.

### [Specification]

Wrench rotation operating pressure	2.0 ~ 7.0MPa (20~70 kgf/cm <sup>2</sup> )
Wrench torque	147~510Nm (15~52 kgf·m)
Flow	~30 ℓ /min
Rotation speed	~37 min <sup>-1</sup>
Weight	75kg

### [Special specification]

- Airblow Unit
- Encoder Unit

## Electric power wrench

- Wrench output torque and wrench rotation speed are optionally set because it is controlled by the inverter.
- The jaw position of the chuck can be detected by the encoder and PLC.
- Hydraulic pressure is not used.

### [Reference Specification]

Motor Capacity	400W	750W
Wrench Output Torque	10~30 kgf · m	20~60 kgf · m
Wrench Rotation Speed	20~100 min <sup>-1</sup>	20~120 min <sup>-1</sup>

Manufacture of specifications other than the above is also available.

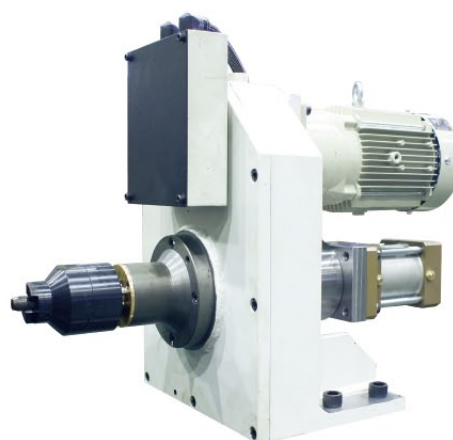

※Photo shows 750W specification

## 3/6-JAW POWER CHUCK FOR LARGE

- Jaw stroke : 30mm (DIA)
- With chip covers for vertical use
- One set of soft jaws are included (Hard top jaws not included)
- Cast iron body
- For Adaptor mounting (OPTIONAL)

**STANDARD TYPE**  
With soft jaws

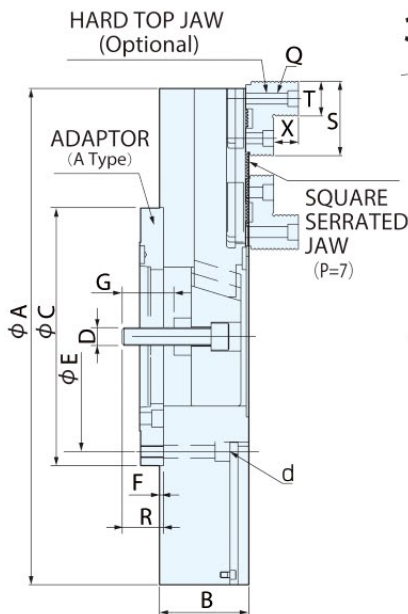
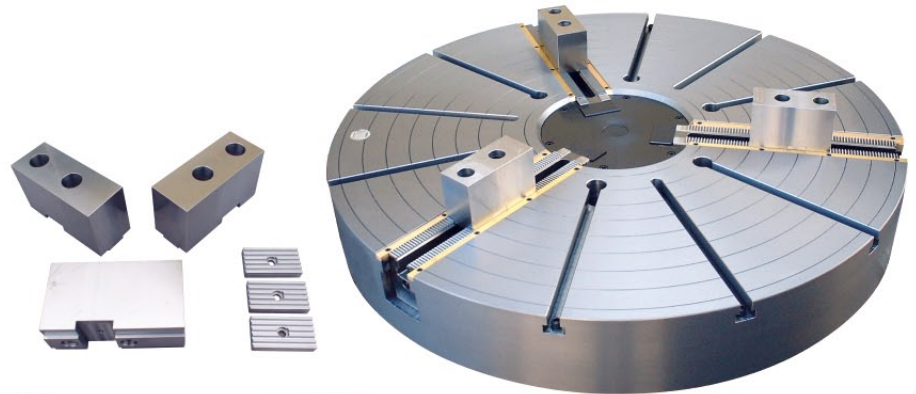

**3-JAW**

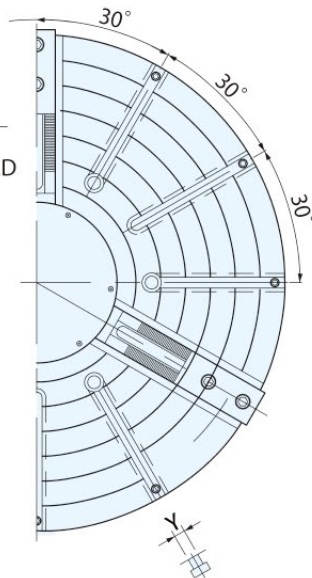

**6-JAW**

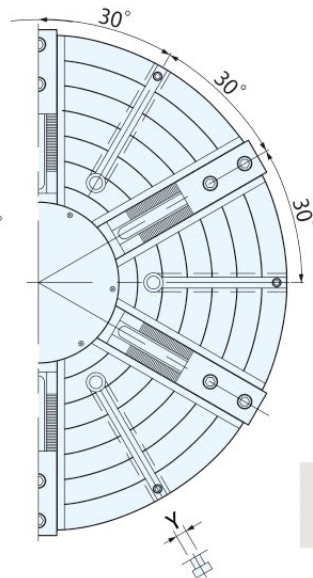

**STANDARD TYPE**  
With soft jaws

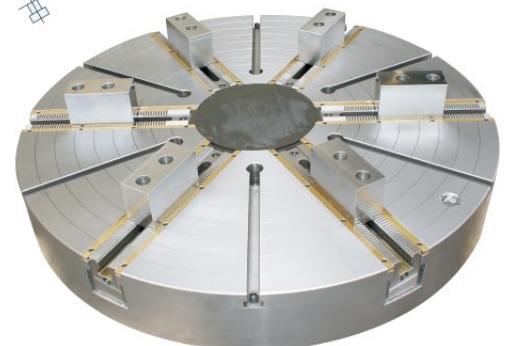

(Hard top jaws are optional.)

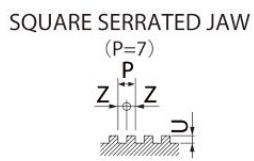

**SOFT JAW (Standard)**

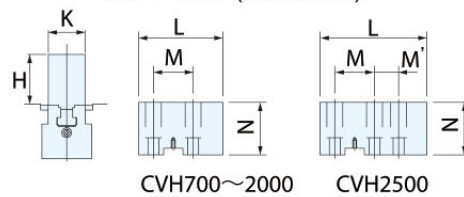

CVH700~2000

CVH2500

## PARTS FOR POWER CHUCK

**HARD TOP JAW**  
(Optional)



**MASTER JAW**



**JAW NUT**



**COVER**



**DRAW RING**



**DRAW BOLT**



**DRAW NUT**

Unit (mm)

MODEL	CVH 700		CVH 800		CVH 1000		CVH 1250		CVH 1400		CVH 1600		CVH 2000		CVH 2500	
	3-JAW	6-JAW	3-JAW	6-JAW	3-JAW	6-JAW	3-JAW	6-JAW	3-JAW	6-JAW	3-JAW	6-JAW	3-JAW	6-JAW	3-JAW	6-JAW
A	700		800		1000		1250		1400		1600		2000		2500	
B	170		170		180		180		200		220		250		300	
C (H6)	380 <sup>+0.036</sup> <sub>0</sub>		380 <sup>+0.036</sup> <sub>0</sub>		520 <sup>+0.044</sup> <sub>0</sub>		520 <sup>+0.044</sup> <sub>0</sub>		520 <sup>+0.044</sup> <sub>0</sub>		720 <sup>+0.05</sup> <sub>0</sub>		720 <sup>+0.05</sup> <sub>0</sub>		900 <sup>+0.05</sup> <sub>0</sub>	
E	330.2		330.2		463.6		463.6		463.6		647.6		647.6		800	
F	8		8		8		8		8		8		10		20	
G	60		60		65		65		65		65		75		85	
H	80		80		100		100		100		100		120		150	
K	69		69		74		74		74		74		99		124	
D	M30 (P=3.5)		M30 (P=3.5)		M36 (P=4)		M36 (P=4)		M36 (P=4)		M36 (P=4)		M42 (P=4.5)		M48 (P=5)	
R	40~90		40~90		44~94		44~94		24~74		4~54		21~71		26~86	
Q	M20		M20		M20		M20		M20		M20		M24 (2pcs.)		M24 (2pcs.)	
S	120		120		150		150		150		150		180		250	
T	50		50		70		70		70		70		85		100	
X	40		40		50		50		50		50		60		80	
L	150		150		170		170		170		170		200		260	
M(M')	70		70		80		80		80		80		100		M=115, M'=55	
N	86		86		106		106		106		106		127		159	
P	7		7		7		7		7		7		7		10	
Z	3.5		3.5		3.5		3.5		3.5		3.5		3.5		5	
U	3		3		3		3		3		3		3		4.5	
Y	22		22		22		22		22		22		28		28	
d	6-M22		6-M22		6-M24		6-M24		6-M24		6-M24		6-M30		6-M42	

MODEL	CVH 700		CVH 800		CVH 1000		CVH 1250		CVH 1400		CVH 1600		CVH 2000		CVH 2500	
	3-JAW	6-JAW	3-JAW	6-JAW	3-JAW	6-JAW	3-JAW	6-JAW	3-JAW	6-JAW	3-JAW	6-JAW	3-JAW	6-JAW	3-JAW	6-JAW
Jaw Stroke (DIA) mm	30		30		30		30		30		30		30		36	
Plunger Stroke mm	50		50		50		50		50		50		50		60	
※ Gripping DIA	MAX mm		705		875		1110		1265		1460		1840		2300	
	MIN mm		300		380		450		520		560		785		990	
Allowable Plunger Force kN(kgf)	64 (6500)		64 (6500)		82 (8400)		82 (8400)		82 (8400)		82 (8400)		98 (10000)		196 (20000)	
Max. Gripping Force kN(kgf)	118 (12000)		118 (12000)		152 (15500)		152 (15500)		152 (15500)		152 (15500)		186 (19000)		323 (33000)	
Max. Speed min <sup>-1</sup>	750 550		650 450		480 340		360 270		300 240		240 200		150		100	
GD <sup>2</sup> kN·m <sup>2</sup> (kgf·m <sup>2</sup> )	8.6 1 (86) (98)		1.4 1.6 (150) (157)		3 3.2 (300) (325)		6.5 6.9 (664) (703)		12.8 13.2 (1303) (1343)		22.3 22.6 (2278) (2304)		57 62.5 (5820) (6380)		164.5 179.5 (16780) (18310)	
Weight kg	350 400		470 490		600 650		850 900		1330 1370		1780 1800		2910 3190		5370 5860	
Adaptor A Type (Optional)	A-11, A-15		A-11, A-15		A-11, A-15 A-20		A-11, A-15 A-20		A-11, A-15 A-20		A-15, A-20		A-15, A-20		A-15, A-20	
Soft Jaw	SJV-150		SJV-150		SJV-170		SJV-170		SJV-170		SJV-170		SJV-200		SJV-260	

※The gripping diameter is reference value when soft jaws are bored.

POWER CHUCK

## POWER CHUCK WITH BORING MILL JAWS

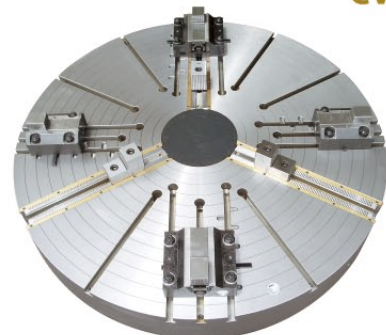
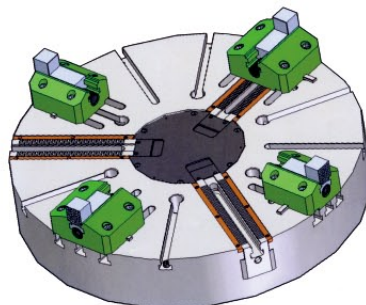
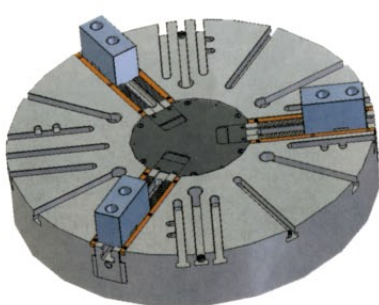
SERIES  
CVB

※Manufacture of power chuck with boring mill jaws (CVB type) is also available at your request.

## 4-JAW COMBINATION CHUCK

- It is structured so that respective jaws can be individually operated and irregular shaped objects can be gripped powerfully.
- With chip cover for vertical use
- Cast iron body
- One set of hard top jaws are included (Soft jaws not included)

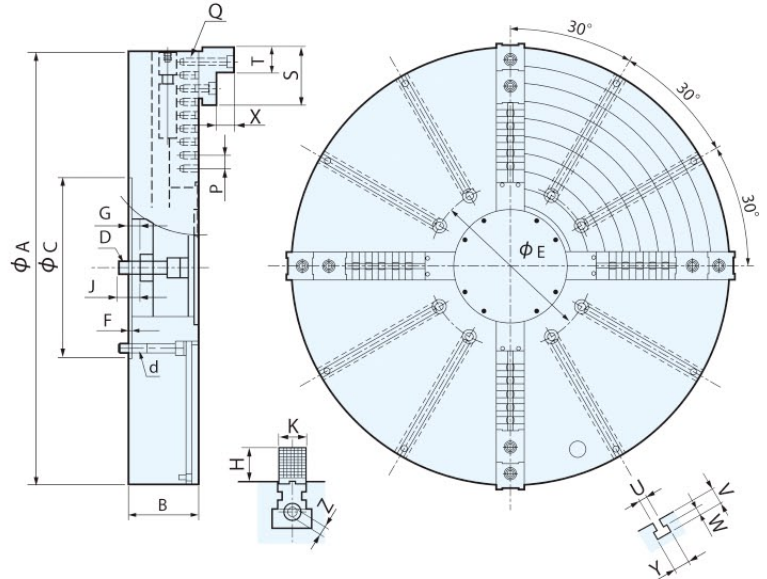
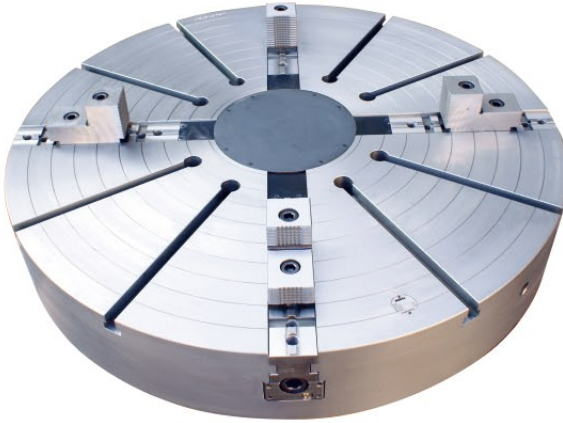

Unit (mm)

MODEL	CVA 800	CVA 1000	CVA 1250	CVA 1400	CVA 1600	CVA 1800	CVA 2000
A	800	1000	1250	1400	1600	1800	2000
B	180	200	200	200	220	250	250
C (H6)	380 <sup>+0.036</sup> <sub>0</sub>	520 <sup>+0.044</sup> <sub>0</sub>	520 <sup>+0.044</sup> <sub>0</sub>	520 <sup>+0.044</sup> <sub>0</sub>	720 <sup>+0.05</sup> <sub>0</sub>	720 <sup>+0.05</sup> <sub>0</sub>	720 <sup>+0.05</sup> <sub>0</sub>
E	330.2	463.6	463.6	463.6	647.6	647.6	647.6
F	8	8	8	8	8	10	10
D	M30 (P=3.5)	M36 (P=4)	M36 (P=4)	M36 (P=4)	M36 (P=4)	M42 (P=4.5)	M42 (P=4.5)
G	28	34	34	34	54	54	54
J	60	65	65	65	65	75	75
H	92	100	100	100	100	115	115
K	69	79	79	79	79	99	99
P	38.1	38.1	38.1	38.1	38.1	76.2	76.2
Q	M 20	M 22	M 22	M 22	M 22	M 24	M 24
S	140	170	170	170	170	180	180
T	65	75	75	75	75	85	85
X	46	50	50	50	50	60	60
Z	19 (Quad.)	26 (Hex.)	26 (Hex.)	26 (Hex.)	26 (Hex.)	26 (Hex.)	26 (Hex.)
U	22	22	22	22	22	28	28
V	38	38	38	38	38	48	48
W	16	16	16	16	16	20	20
Y	37	37	37	37	37	48	48
d	8-M22	8-M24	8-M24	8-M24	8-M24	8-M30	8-M30

MODEL	CVA 800	CVA 1000	CVA 1250	CVA 1400	CVA 1600	CVA 1800	CVA 2000	
Individual Jaw Stroke(One side)	42.5	45	45	45	45	85	85	
Auto Jaw Stroke(DIA)	30	30	30	30	30	30	30	
Plunger Stroke	50	50	50	50	50	50	50	
Gripping DIA	Outside	φ 300~φ 680	φ 380~φ 870	φ 400~φ 1120	φ 410~φ 1270	φ 450~φ 1465	φ 545~φ 1640	φ 745~φ 1840
	Inside	φ 410~φ 640	φ 515~φ 830	φ 535~φ 1080	φ 535~φ 1230	φ 580~φ 1430	φ 700~φ 1620	φ 900~φ 1820
Allowable Plunger Force kN (kgf)	64 (6500)	82 (8400)	82 (8400)	82 (8400)	82 (8400)	98 (10000)	98 (10000)	
Max. Gripping Force kN (kgf)	118 (12000)	152 (15500)	152 (15500)	152 (15500)	152 (15500)	186 (19000)	186 (19000)	
Max. Speed min <sup>-1</sup>	450	360	300	260	230	190	150	
GD <sup>2</sup> kN · m <sup>2</sup> (kgf · m <sup>2</sup> )	1.6 (163)	3.9 (395)	9.6 (976)	14 (1421)	25 (2560)	43.7 (4455)	61.7 (6300)	
Weight kg	510	790	1250	1450	2000	2750	3150	
Soft Jaw	SJ-160	SJ-170	SJ-170	SJ-170	SJ-170	SJ-170	SJ-170	

※Manufacture of 3-jaw and 6-jaw chucks is also available at your request.

## 3-JAW POWER CHUCK FOR LATHE

- Jaw stroke : 18.6mm (DIA)
- With chip covers
- Cast iron body
- One set of soft jaws are included ( Hard top jaws not included)
- For direct mounting on Type A spindle nose

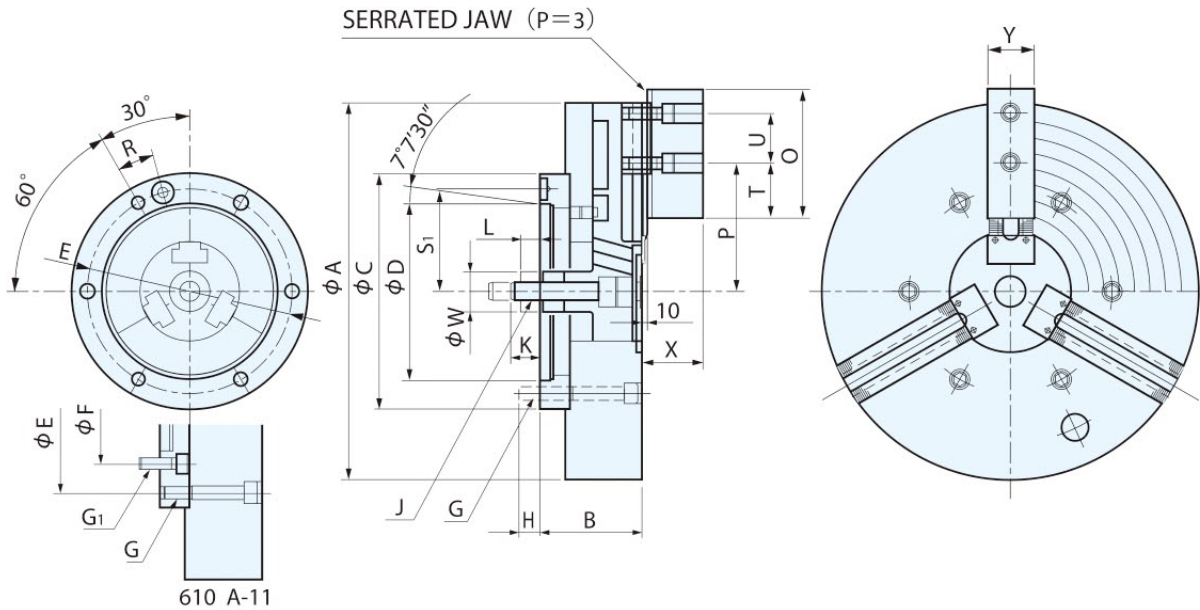

Unit (mm)

MODEL	CV 530	CV 610
Spindle Nose	A1 . A2 - 11	A1 . A2 - 11 A1 . A2 - 15
A	530	610
B	165	175
C	300	380
D	196.869	285.775
E	235	330.2
F	—	235
G	M20	M22
G <sub>1</sub>	—	M20
H	30	33.5
J	M30 P3.5	
K	40~80	35~70
L	-5~30	-15~20
O	180	210
U	60	80
T	80	90
P	MAX	207.5
	MIN	111.5
R	30°	15°
S <sub>1</sub>	117.5	165.1
W	65	
X	78	98
Y	65	74

### ADAPTOR (OPTIONAL)

A Type	CV530-BP-A11	CV610-BP-A11	CV610-BP-A15
--------	--------------	--------------	--------------

MODEL	CV 530	CV 610
Jaw Stroke DIA (mm)	18.6	
Plunger Stroke (mm)	35	
※ Gripping DIA (mm)	MAX	490
	MIN	70
Max. Speed (min <sup>-1</sup> )	1000	850
Allowable Plunger Force (kN)	49	
Gripping Force (kN)	108	
G D <sup>2</sup> (kgf · m <sup>2</sup> )	28	46.5
Weight (kg)	200	250
Cylinder	φ 150 × 35L	
Soft Jaw	SHJ-18	SHJ-24

※The gripping diameter is reference value when soft jaws are bored.



## LONG STROKE TYPE

- Jaw stroke total 50mm
- With chip cover
- Large rotation speed
- For adaptor mounting
- Cast iron body

[SPECIFICATION]

Jaw Stroke (DIA)	50 mm
Plunger Stroke	50 mm
Allowable Plunger Force	59 kN (6500kgf)
Gripping Force	95 kN (9700kgf)

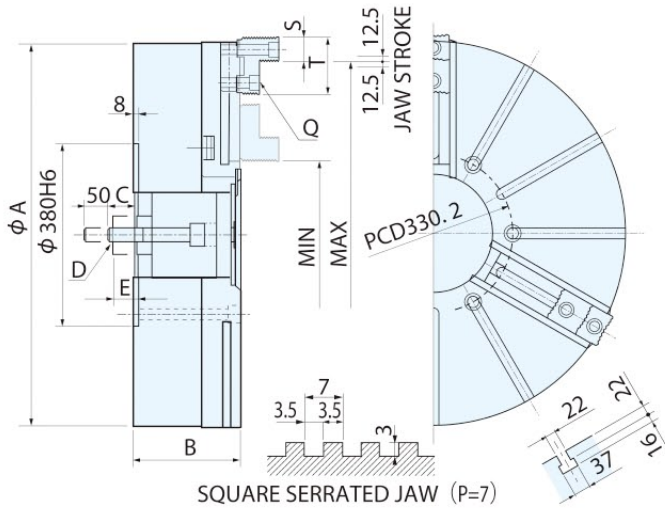

MODEL	A	B	C	D	E	Q	S	T	Gripping Range		Max. Speed min <sup>-1</sup>	Weight (kg)
									MIN	MAX		
CLK 800	800	220	60	M30	45	M20	50	120	315	700	770	530
CLK1000	1000	235	60	M36	45	M20	70	150	330	850	550	900
CLK1200	1200	250	60	M36	45	M20	70	150	360	1100	410	1500

MODEL	Soft Jaw	Unit (mm)				
		H	K	L	M	N
CLK 800	SJV-150	80	69	150	70	86
CLK1000	SJV-170	100	74	170	80	106
CLK1200	SJV-170	100	74	170	80	106

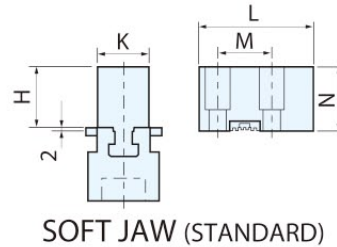

※Design and manufacture of hydraulic chucks suitable for workpieces are available at your request.

## 6-JAW (3+3) POWER CHUCK

- With chip covers for vertical use
- As three jaw (①) function in the centripetal direction and the remaining three jaws individually function (②), these jaws can powerfully grip thin objects and irregular shaped objects.

- ①Jaw Jaw stroke (one side) : 15mm  
Maximum gripping force : 152kN
- ②Jaw Jaw stroke (one side) : 20mm  
Maximum gripping force : 39kN

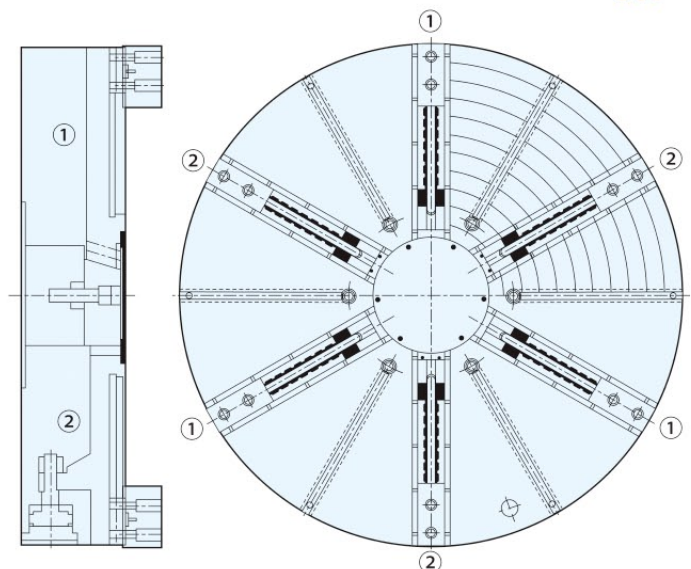



# 4-JAW POWER CHUCKS

## 4-JAW (2+2) POWER CHUCK

- Irregularly shaped parts (e.g. those which are almost but not exactly round, square, oval, etc.) can be gripped securely due to the centripetal action of the two parts of jaws which are mounted crosswise.
- With chip covers
- Long jaw stroke, Large gripping range
- Cast iron body
- One set of soft jaws included (Hard top jaws not included)

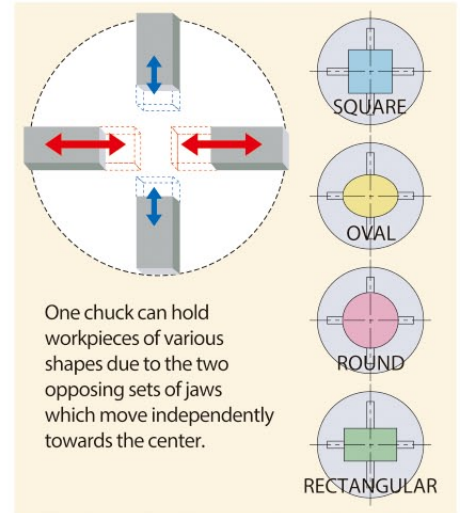
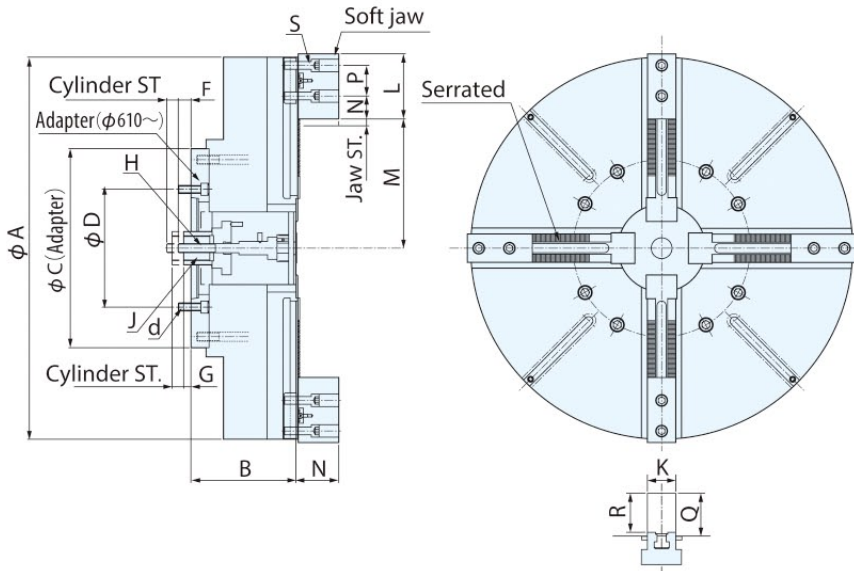

MODEL	4HA 18	4HA 21	4HA 24	4HA 28	4HA 32	4HA 40	4HA 50	4HA 55	4HA 63	4HA 71	4HA 79	Unit (mm)
A	460	530	610	710	810	1000	1250	1400	1600	1800	2000	
B	210	210	275	275	275	275	325	325	325	385	385	
C	(direct mount)	(direct mount)	520	520	520	520	520	520	520	720	720	
D	A2-11	235	235	235	235	235	-	-	-	-	-	
	A2-15	-	-	330.2	330.2	330.2	330.2	330.2	330.2	330.2	330.2	
	A2-20	-	-	-	-	-	463.6	463.6	463.6	463.6	463.6	
d	A2-11	4-M20 (divided equally)	4-M20 (divided equally)	8-M20	8-M20	8-M20	8-M20	-	-	-	-	
	A2-15	-	-	8-M24	8-M24	8-M24	8-M24	8-M24	8-M24	8-M24	8-M24	
	A2-20	-	-	-	-	-	8-M24	8-M24	8-M24	8-M24	8-M24	
F	10~35	10~35	5~35	5~35	5~35	5~35	15~45	15~45	15~45	43~83	43~83	
G	0~25	0~25	5~35	5~35	5~35	5~35	15~45	15~45	15~45	43~83	43~83	
H	M24 P3.0	M24 P3.0	M24 P3.0	M24 P3.0	M24 P3.0	M24 P3.0	M30 P3.5	M30 P3.5	M30 P3.5	M42P4.5	M42P4.5	
J	M55 P1.5	M55 P1.5	M55 P1.5	M55 P1.5	M55 P1.5	M55 P1.5	M75 P2.0	M75 P2.0	M75 P2.0	M100 P3.0	M100 P3.0	
K	62	62	69	69	69	74	74	74	74	99	99	
L	165	165	150	150	150	170	170	170	170	200	200	
M	MIN	61	61	109	110	113	114	124	129	131	144	146
	MAX	103	138	172	222	260	338	460	535	635	710	810
N	75	75	55	55	55	60	60	60	60	60	60	
P	43	43	70	70	70	80	80	80	80	100	100	
Q	75.2	75.2	92	92	92	112	112	112	112	132	132	
R	65.2	65.2	82	82	82	102	102	102	102	122	122	
S	M20	M20	M20	M20	M20	M20	M20	M20	M20	M24	M24	
Jaw Stroke (Radius)	10	10	14	14	14	14	15	15	15	20	20	
Cylinder ST.	25	25	30	30	30	30	30	30	30	40	40	
Serration pitch	1.5	1.5	7	7	7	7	7	7	7	7	7	
Allowable Cyl. Force kN	27	27	43	43	43	43	64	64	64	88	88	
Gripping Force (4pcs. jaw) kN	92	92	125	125	125	125	153	153	153	200	200	
Max. Rotation Speed min <sup>-1</sup>	950	840	770	660	610	450	350	290	230	190	150	
Weight kg	A2-11	210	260	540	680	700	870	-	-	-	-	
	A2-15	-	-	530	670	690	860	1420	1640	1910	3250	3700
	A2-20	-	-	-	-	-	840	1400	1620	1890	3220	3670
Soft Jaw	HO-15	HO-15	SJV-150	SJV-150	SJV-150	SJV-170	SJV-170	SJV-170	SJV-170	SJV-200	SJV-200	
Cylinder	HW-1325	HW-1325	HW-1530	HW-1530	HW-1530	HW-1530	HW-1830	HW-1830	HW-1830	HW-2040	HW-2040	

## Solutions for ring machining

[FEATURE]

### ■ FLC series

- Long jaw stroke 86mm (DIA)
- Centrifugal force compensation
- With chip cover for vertical use

### ■ FCH series

- Jaw stroke 28.6mm (DIA)
- Pitch 7mm square serration
- With chip cover for vertical use

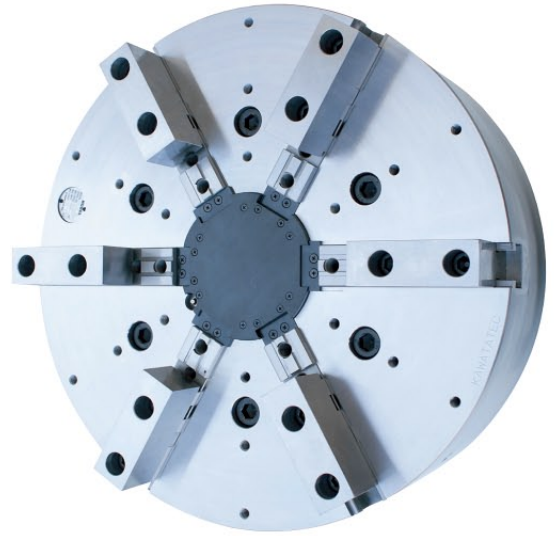

### Floating function

- Floating function included inside the chuck.
- Allows for equal clamping at 6 points in the first process of ring materials with low circularity. (\*Our experimental data reveals that circularity is improved on average by four times with respect to general 6-jaw chucks.)

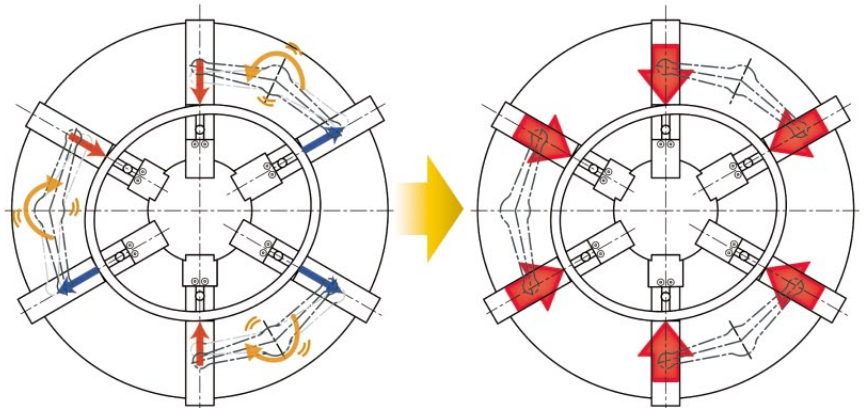

Adjacent jaws are equalized in accordance with the shape of a workpiece.

Six jaws clamp a workpiece with equal force.

### 12-jaw floating spec with pendulum jaw

- Each floating jaw is attached with a pendulum jaw and clamped equally at 12 points to realize greater improvement in circularity. (\*Our experimental data reveals that circularity is improved on average by 6.5 times with respect to general 6-jaw chucks.)

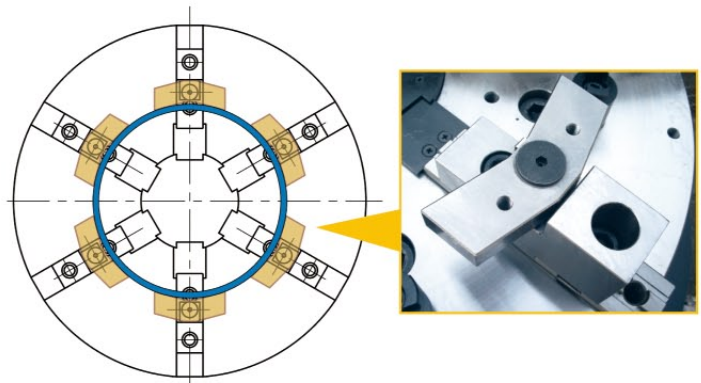

### Centrifugal force compensation function (FLC Series)

- Decrease in gripping force due to rotation is approximately one-fifth of that of conventional hydraulic chucks. If a thin workpiece is chucked loosely due to concerns about deformation, there are no concerns about a flying out workpiece.

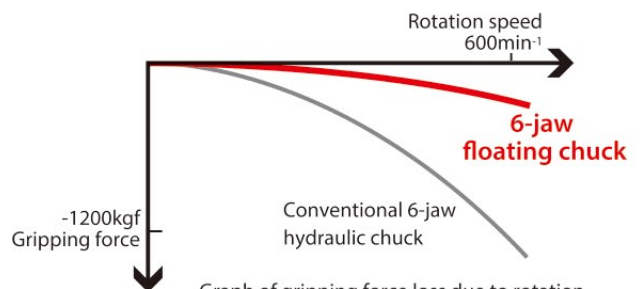

Graph of gripping force loss due to rotation  
\*At maximum gripping position / When soft jaw used

POWER CHUCK

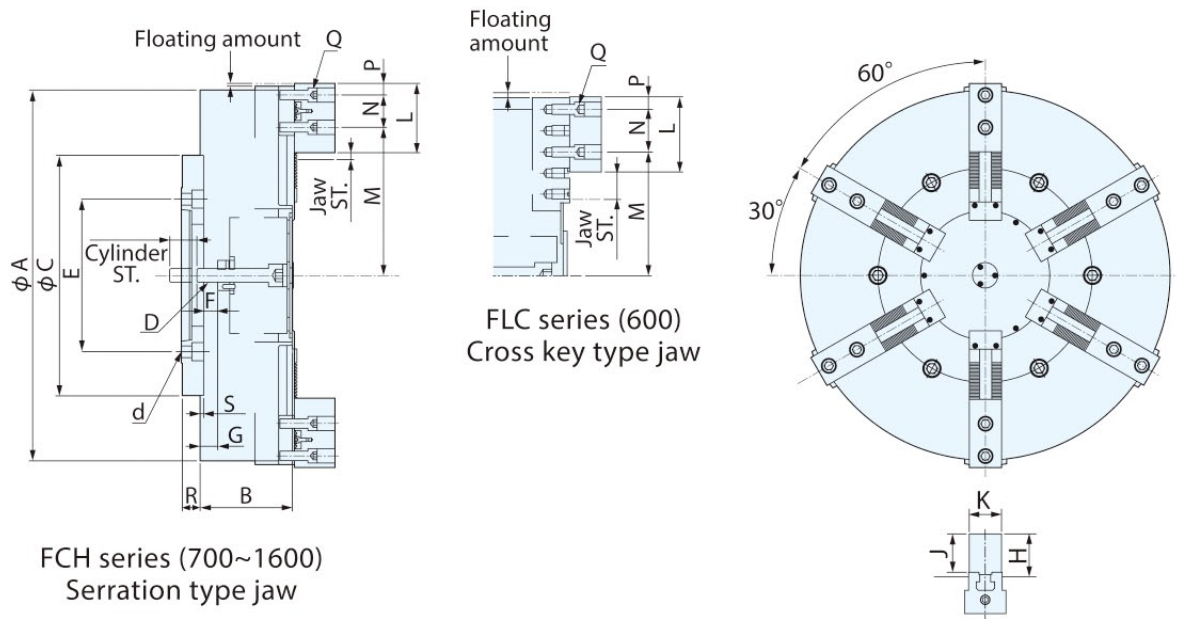

FCH series (700~1600)  
Serration type jaw

FLC series (600)  
Cross key type jaw

Unit (mm)

MODEL	FLC 600	FCH 700	FCH 800	FCH 1000	FCH 1250	FCH 1400	FCH 1600
A	600	700	800	1000	1250	1400	1600
B	200	200	200	200	210	210	220
C	380	520	520	520	520	520	520
E	A2-11	235	235	235	235	235	235
	A2-15	330.2	330.2	330.2	330.2	330.2	330.2
	A2-20	-	463.6	463.6	463.6	463.6	463.6
d	A2-11	6-M20	8-M20	8-M20	8-M20	8-M20	8-M20
	A2-15	6-M24	8-M24	8-M24	8-M24	8-M24	8-M24
	A2-20	-	8-M24	8-M24	8-M24	8-M24	8-M24
D	M30 P3.5	M30 P3.5	M30 P3.5	M36 P4	M36 P4	M36 P4	M36 P4
F	50	60	60	65	65	65	65
G	24	39	39	39	49	49	59
H	68	92	92	112	112	112	112
J	60	82	82	102	102	102	102
K	45	69	69	74	74	74	74
L	135	150	150	170	170	170	170
M	MIN	113	175	176	198	204	239
	MAX	213	260	310	389	514	689
N	76.2	70	70	80	80	80	80
P	22.39	25	25	30	30	30	30
Q	M16	M20	M20	M20	M20	M20	M20
R	40	40	40	40	40	40	40
S	8	8	8	8	8	8	8
Jaw Stroke (DIA)	43	14.3	14.3	14.3	14.3	14.3	14.3
Cylinder ST.	50	50	50	50	50	50	50
Floating amount	±2	±1.5	±1.5	±2	±2	±2	±2
Allowable Cyl. Force kN	108	64	64	82	82	82	82
Gripping Force kN	68	127	127	166	166	166	166
Max. Speed min <sup>-1</sup>	850	560	500	430	350	290	230
Weight kg	ST	360	-	-	-	-	-
	A2-11	397	545	665	915	1315	1965
	A2-15	391	530	650	900	1300	1950
	A2-20	-	510	630	880	1280	1930
Soft Jaw	SJ-135	SJV-150	SJV-150	SJV-170	SJV-170	SJV-170	SJV-170
Cylinder	HS2050SC	HS2050SC	HS2050SC	HS2050SC	HS2050SC	HS2050SC	HS2050SC

# POWER CHUCK WITH EXTRA LARGE BORE THROUGH HOLE

**SERIES NHR**

Optimal for short-length shaft machining

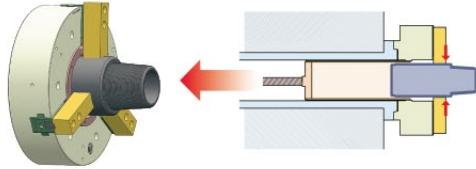

The workpiece is partially stored in the spindle, and the nearby part to be machined is held firmly.



※ For NHR 650, 760 and 810, the upper surface is not provided with T-slot, but TAP hole is adopted.

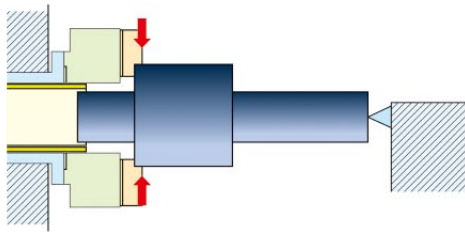

The end part of workpiece is stored in the chuck, and large diameter part is clamped so as to allow for stable machining. In addition, long shape workpiece can be machined with smaller machine.

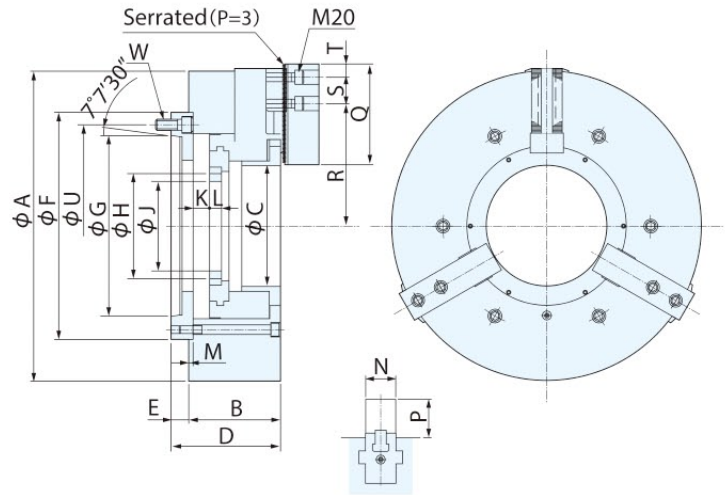

Unit (mm)

MODEL	A	B	C	D	E	F	G		H	J	K	L	M	N	P	Q	R		S
							A2-15	A2-20	MAX.								min.-max.		
<b>NHR 610-230</b>	610	210	230	250	40	520	285.775	412.775	M220	180	38	27	10	69	88	230	215-233	60	
<b>NHR 650-266</b>	650	185	266	227	42	520	285.775	412.775	M270	165	40	35	8	69	88	230	217-255	60	
<b>NHR 710-277</b>	710	210	277	250	40	520	285.775	412.775	M270	206	38	27	10	69	88	230	239-280	60	
<b>NHR 760-266</b>	760	185	266	227	42	520	285.775	412.775	M270	165	40	35	8	69	88	230	217-300	60	
<b>NHR 810-266</b>	810	185	266	227	42	520	285.775	412.775	M270	165	40	35	8	69	88	230	218-325	60	

MODEL	T	U		W		Jaw stroke (radius)	Cylinder stroke	Allowable CYD. Force kN	Max Gripping Force kN	Max. Rotation Speed min <sup>-1</sup>	Weight kg	
		A2-15	A2-20	A2-15	A2-20						A2-15	A2-20
<b>NHR 610-230</b>	30	330.2	463.6	Divided equally into 6 portions - M24		9.3	35	63.7	118	850	510	495
<b>NHR 650-266</b>	30	330.2	463.6			9.3	35	88.2	196	1020	430	415
<b>NHR 710-277</b>	30	330.2	463.6			9.3	35	88.2	196	890	615	600
<b>NHR 760-266</b>	30	330.2	463.6			9.3	35	88.2	196	870	600	585
<b>NHR 810-266</b>	30	330.2	463.6			9.3	35	88.2	196	820	680	665

Optimal for machining of flange with vertical machining center

[FEATURE]

- Equipped with a built-in air cylinder
- Low profile
- One set of soft jaws included

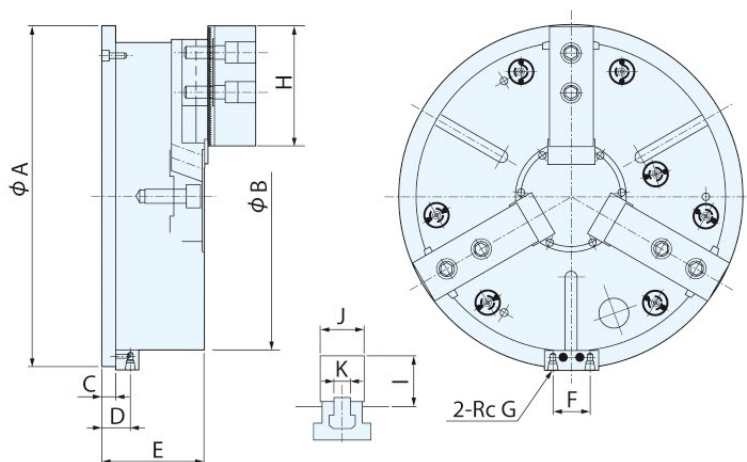
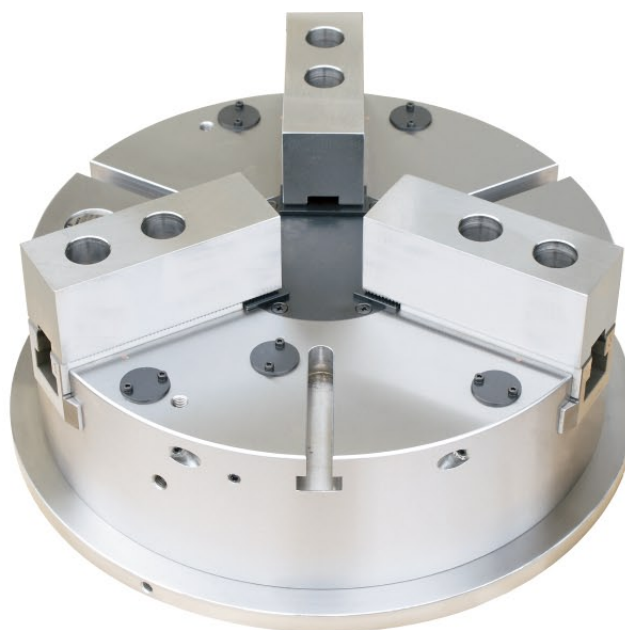
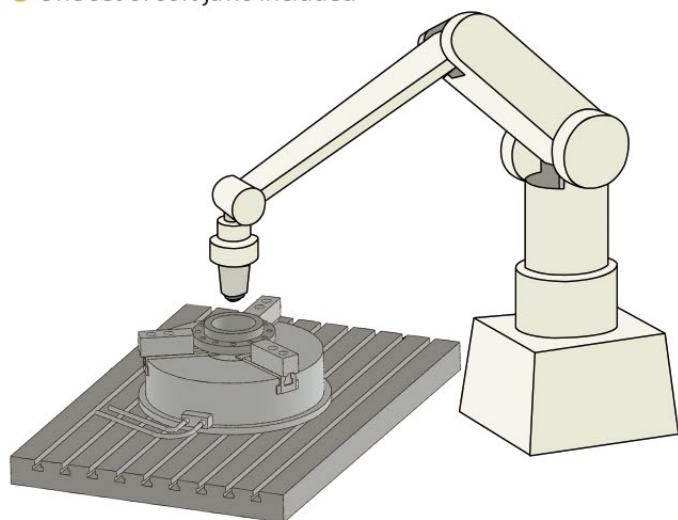

POWER CHUCK

MODEL	A	B	C	D	E	F	G	H	I	J	K	Jaw stroke (DIA)	Gripping DIA (outside)		Max Operating pressure MPa	Gripping Force kN
													Max.	Min.		
<b>ASM 460</b>	510	460	20	42.5	153	55	3/8	180	75.5	64	25	14.5	460	100	0.5	68
<b>ASM 500</b>	550	500	22	44.5	157	55	3/8	180	77	64	25	14.5	500	110	0.5	70
<b>ASM 600</b>	650	600	24	46.5	176	60	1/2	180	77	64	25	16	600	130	0.5	125

MODEL	Piston area cm <sup>2</sup>		Piston Stroke (Max.)	Weight kg	Soft jaw
	Extend	Retract			
<b>ASM 460</b>	1074	931	20	185	SHJ-18
<b>ASM 500</b>	1256	1079	20	210	SHJ-18
<b>ASM 600</b>	1962	1761	22	330	SHJ-18

# COMPACT SIZED HYDRAULIC CYLINDER

**TYPE HS**

- Applicable for CVH, CVA, CLK series
- Compact form is suitable for use on vertical lathe



MODEL		<b>HS2050SC</b>	
Cylinder inner diameter	200 mm	Max. operation pressure	3.5 MPa
Piston Stroke	50 mm	Moment of inertia	0.375 kg·m <sup>2</sup>
Piston area	Extend	314 cm <sup>2</sup>	Flow rate required for rapid traverse (※) 0.3 L/min
	Retract	298 cm <sup>2</sup>	
Max. speed	1500 min <sup>-1</sup>	Weight	50 kg
※ Operation pressure: 3Mpa Outlet oil temperature : 50°C			

- Standard equipment with check valves, pressure limiting valves and detection switches of stroke end

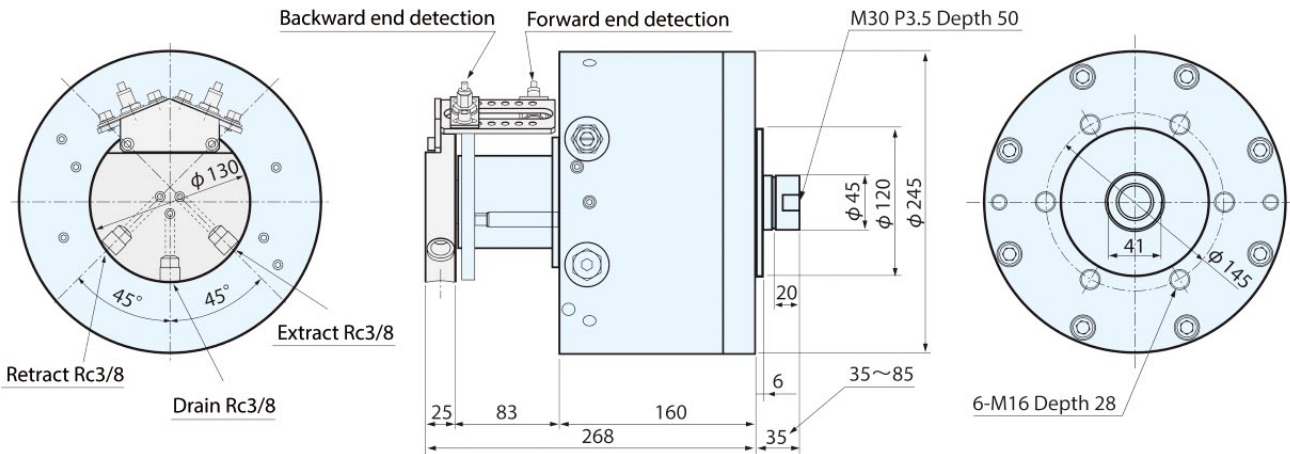

# DOUBLE ROTARY CYLINDER

**TYPE HW**

- Standard equipment with check valves, pressure limiting valves and detection switches of stroke end

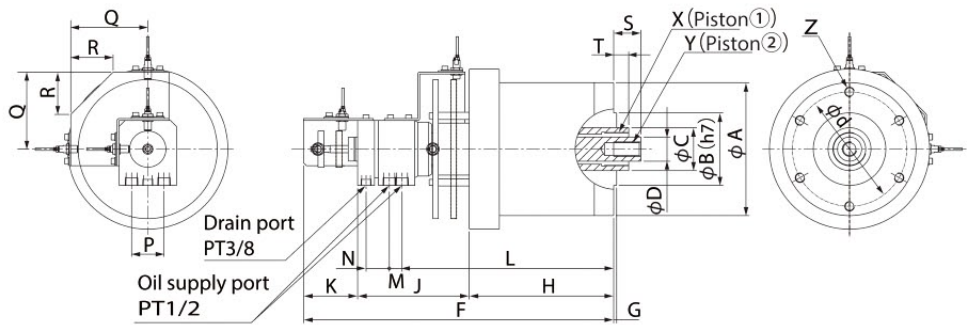

Unit (mm)

MODEL	A	B	C	D	F	G	H	J	K	L	M	N	P	Q	R	S	T	X	Y
<b>HW-1325 SCR</b>	185	110	70	40	476	5	218	174.5	83.5	319	21	38.5	55	127.4	70	45~70	25~50	M55(P1.5)×35L	M24(P3)×50L
<b>HW-1530 SCR</b>	265	120	71	40	513	5	249	174.5	89.5	350	21	38.5	55	127.4	70	45~75	25~55	M55(P1.5)×40L	M24(P3)×50L
<b>HW-1830 SCR</b>	320	150	100	50	529	8	265	174.5	89.5	366	21	38.5	55	142.4	70	50~80	20~50	M75(P2.0)×55L	M30(P3.5)×60L
<b>HW-2040 SCR</b>	360	200	125	70	579	8	305	174.5	99.5	406	21	38.5	55	157.4	70	75~115	35~75	M100(P3)×60L	M42(P4.5)×84L

MODEL	Z (equally divided)	d	Max. operation pressure	Piston stroke	Max. speed min <sup>-1</sup>	Weight kg	Piston area cm <sup>2</sup>		Piston thrust (When Max. operation pressure) kN					
							Piston① Retract	Piston① Extend	Piston② Retract	Piston② Extend	Piston① Retract	Piston① Extend	Piston② Retract	Piston② Extend
<b>HW-1325 SCR</b>	6-M12×24L	155	2.5MPa	25mm	1200	60	115.5	117.9	127.9	129.3	28.3	28.9	31.3	31.7
<b>HW-1530 SCR</b>	6-M16×32L	230	3.0MPa	30mm	800	80	161.5	175	161.9	173.3	47.5	51.5	47.6	51
<b>HW-1830 SCR</b>	6-M20×35L	280	3.5MPa	30mm	600	110	235.6	255.2	232.6	251.1	80.8	87.5	79.8	86.1
<b>HW-2040 SCR</b>	6-M24×35L	320	4.0MPa	40mm	400	150	274.9	308.8	273.4	310.8	107.8	121	107.2	121.8

# CHUCK PALLETS AND PALLET CHANGER FOR VERTICAL LATHES

## CHUCK PALLET



3-JAW SCROLL PALLET



4-JAW INDEPENDENT PALLET

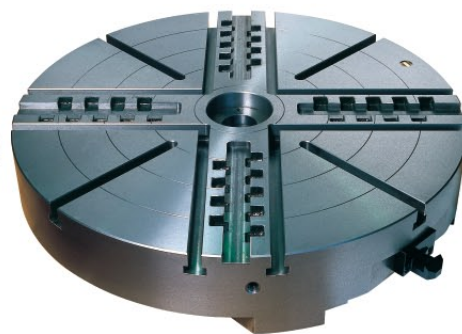

BORING MILL JAW PALLET

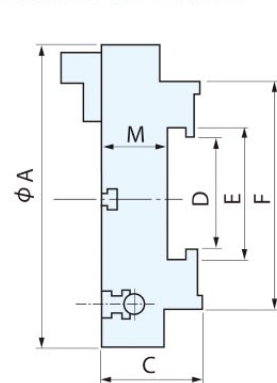
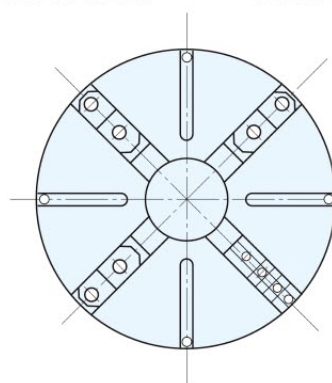
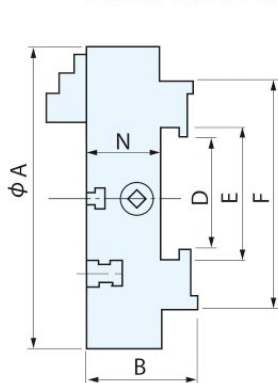
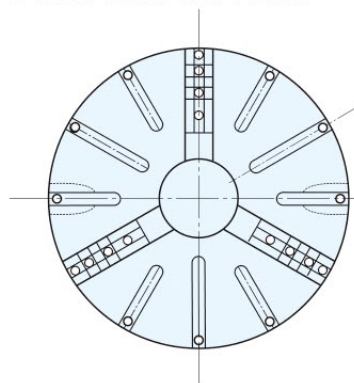

PREFERENCE DIMENSION

								Unit (mm)				
MODEL	A	B	D	E	F	N	Weight (kg)	MODEL	A	C	M	Weight (kg)
<b>610</b>	610	215	220	260	430	150	330	<b>610</b>	610	185	120	250
<b>800</b>	800	255	300	340	540	180	600	<b>800</b>	800	210	135	550
<b>1000</b>	1000	270	380	420	660	195	850	<b>1000</b>	1000	230	145	750
<b>1250</b>	1250	315	500	550	850	220	1600	<b>1250</b>	1250	240	150	1300
<b>1500</b>	1500	330	650	730	980	230	2200	<b>1500</b>	1500	280	180	1900
<b>1700</b>	1700	340	650	730	980	233	2600	<b>1700</b>	1700	300	200	2300

These pallets are available on request and can be manufactured upon consultation. Manufacture of power wrench used type pallets for automatic chucking is also available.

## PALLET CHANGER

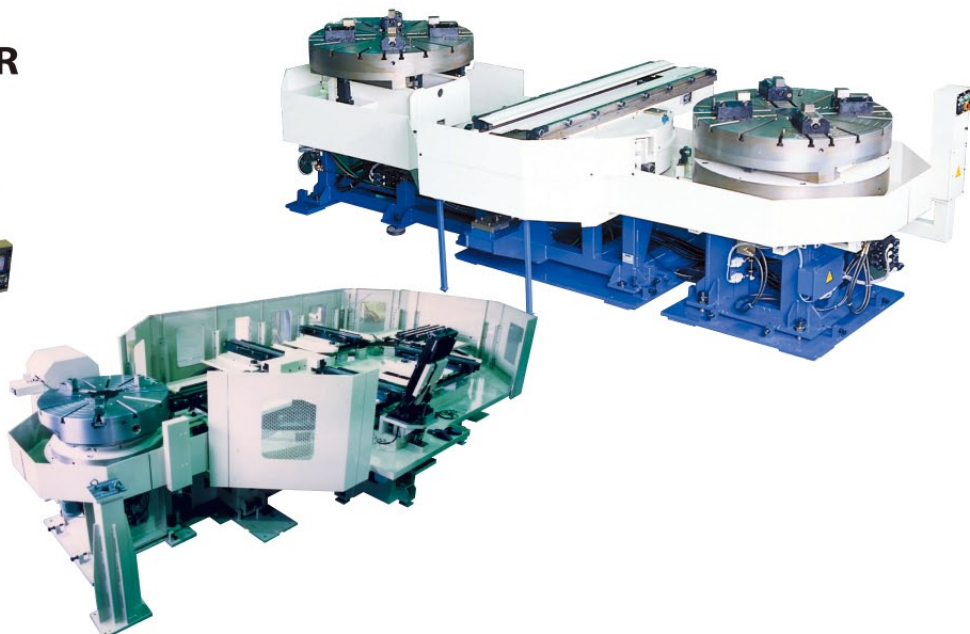

SPECIAL CHUCK

PALLET CHANGER

## 3-JAW SELF-CENTERING CHUCK FOR WELDING POSITIONER

- Easy gripping by simultaneous movement of three jaws due to rotation of the handle
- Strong gripping
- Tapped holes provided on the main body, jaws, and the guide part are used for prevention of the work fixing from shifting
- Low profile and light-weight main body is utilized for machines such as positioners
- Superior in safety and measures taken against intrusion of chips

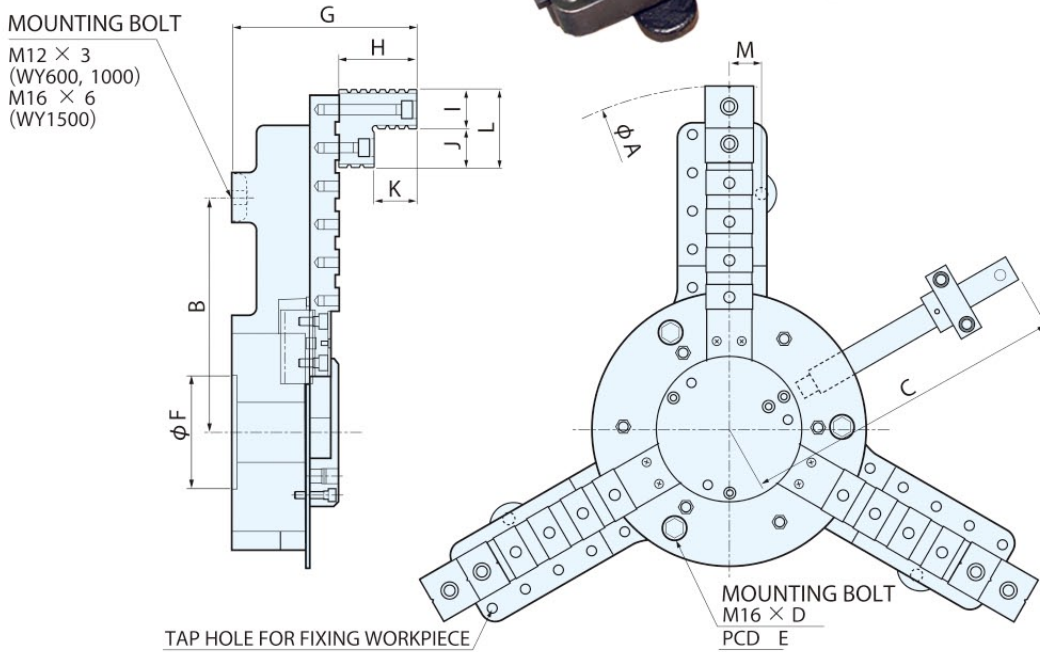
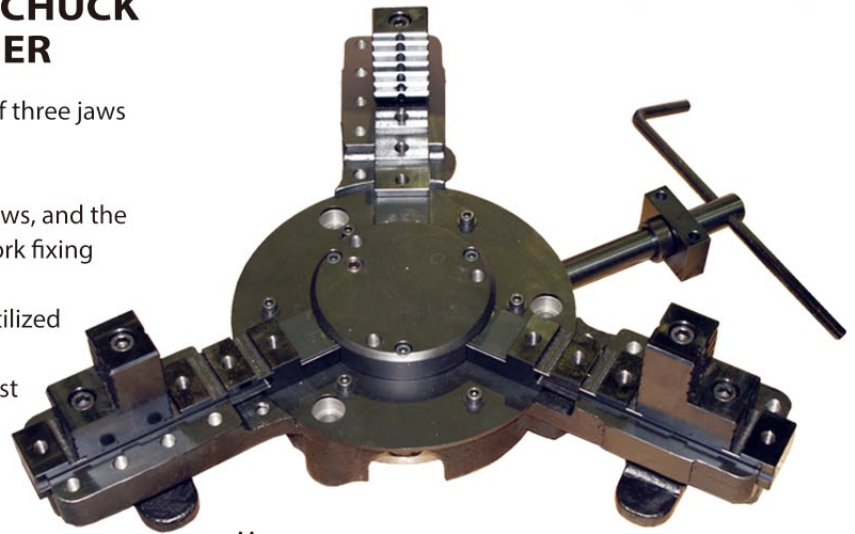

Unit (mm)

MODEL	A	B	C	D	E	F	G	H	I	J	K	L	M
<b>WY 600</b>	726	250	340	3	241.3	120	190.7	80	40	40	45	80	34
<b>WY 1000</b>	1126	430	545	3	241.3	120	190.7	80	40	40	45	80	50
<b>WY 1500</b>	1640	530	692	6	340.4	260	244.5	95	50	50	48	100	85

WELDING CHUCK

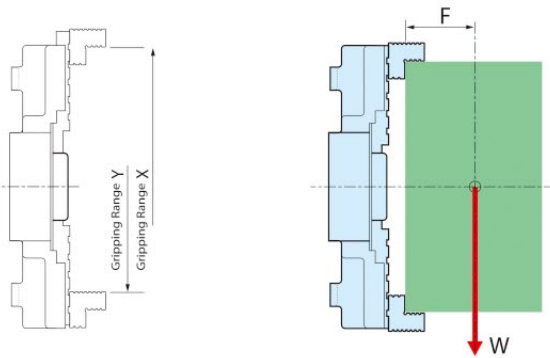

MODEL	Gripping Range Y(mm)	Gripping Range X(mm)	Gripping Force kN (kgf)	F (mm) × W (kg)	Capacity MAX (kg)	Weight (kg)
<b>WY 600</b>	160~560	240~640	20 (2000)	100×400	600kg	58
<b>WY 1000</b>	160~960	240~1040	20 (2000)	100×400	600kg	90
<b>WY 1500</b>	235~1435	335~1535	29 (3000)	100×700	1200kg	230

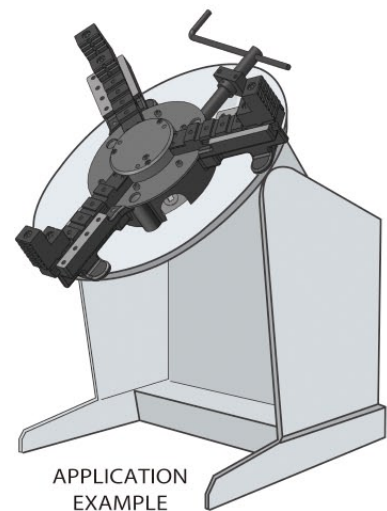



## 3-JAW SELF-CENTERING CHUCK FOR WELDING POSITIONER

- Designed to be lightweight, low profile, with a low center of gravity so as to be easily used for positioners, etc.
- Easily attach/detach a workpiece with its wide gripping range

SERIES WPS

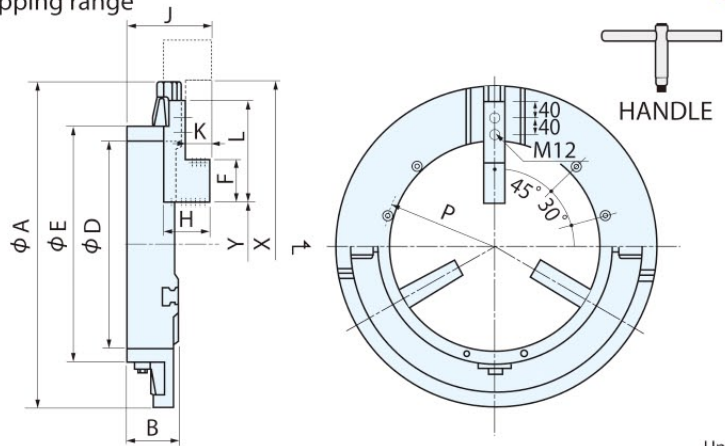
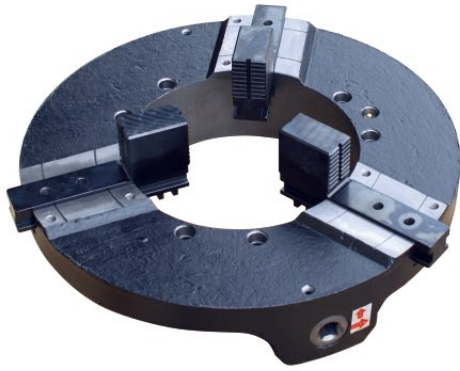

Unit (mm)

MODEL	No.	A	B	D	E	F	H	J	K	L	$\phi P$	Mounting Bolts	Gripping Range	
													Y	X
<b>WPS 500</b>	382040	500	105	270	330	70	100	170	60	200	300	6-M12×100	50~330	330~540
<b>WPS 600</b>	382440	600	105	365	425	70	100	170	60	200	400	6-M12×100	150~400	400~620
<b>WPS 800</b>	383240	800	120	540	600	100	115	195	65	250	575	6-M16×130	250~550	550~830
<b>WPS 1000</b>	384040	1000	135	700	760	100	115	210	65	250	735	6-M16×130	450~750	750~1050
<b>WPS 1200</b>	384740	1200	145	830	900	100	115	220	65	250	865	6-M16×140	600~900	900~1150

Accessories : Handle and Mounting bolts  
Cast iron body

MODEL	Gripping Force kN (kgf)	F × W	Capacity MAX	Weight kg
<b>WPS 500</b>	20 (2000)	100mm×600kg	800 kg	57
<b>WPS 600</b>	20 (2000)	150mm×600kg	1000 kg	87
<b>WPS 800</b>	29 (3000)	200mm×600kg	1500 kg	110
<b>WPS 1000</b>	29 (3000)	250mm×600kg	1500 kg	180
<b>WPS 1200</b>	29 (3000)	300mm×600kg	2000 kg	290

## 3-JAW SELF-CENTERING CHUCK FOR WELDING POSITIONER

- Low profile and low center of gravity, enables large load mounting.
- Smooth rotation is enabled without burden to positioners, etc., because of its small size and lightweight.
- Workpieces detaching is also easy because of its large gripping range.

SERIES WP

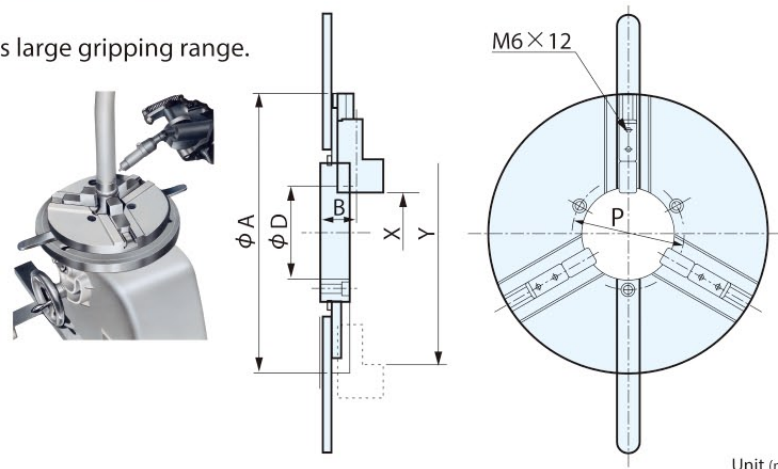
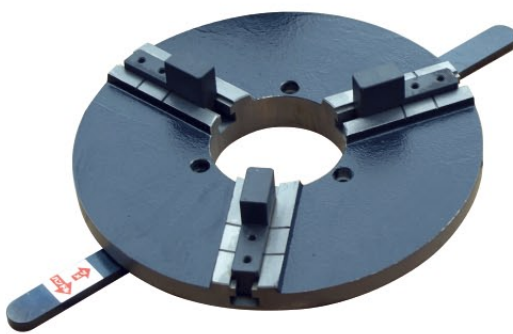

Unit (mm)

MODEL	B	D	$\phi P$	Mounting Bolts	Gripping Range		Gripping Force kN (kgf)	Weight (kg)
					X	Y		
<b>WP 200</b>	39	80	100	M8×35	20~130	110~210	2 (200)	6
<b>WP 300</b>	39	100	120	M8×40	80~190	170~280	2.5 (250)	12
<b>WP 400</b>	45	170	220	M10×40	120~250	250~380	3.5 (350)	24

# AUTOMATIC OPERATED PIPE CATCHER

**PC550 PC840**

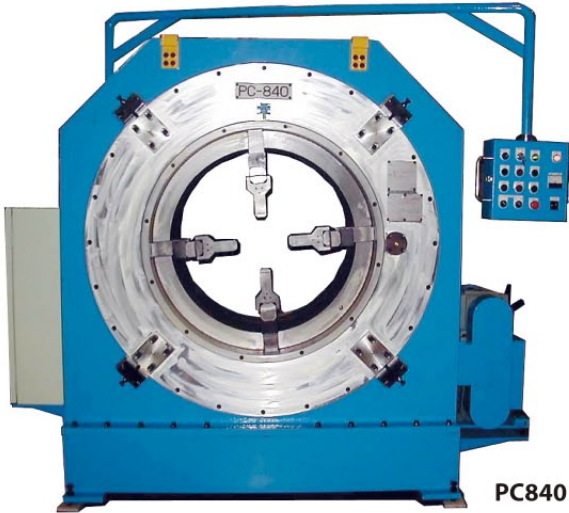

**PC840**

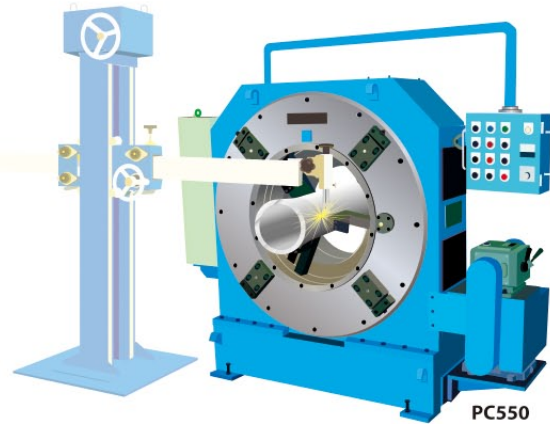

**PC550**

APPLICATION EXAMPLE

- Jaw opening/closing and jaw rotation can be easily operated by a handy button switch
- Rotation speed can be adjusted with the volume dial
- Number of jaws PC550 : 3 jaws, PC840 : 4 jaws (PC840 can grip pipes of more than  $\phi$  60mm by attaching an auxiliary jaw)
- A foot switch is included and pipe rotation is enabled while holding a torch

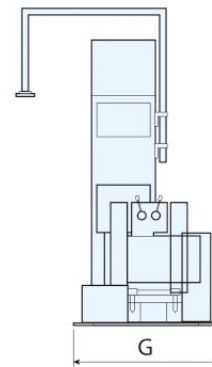
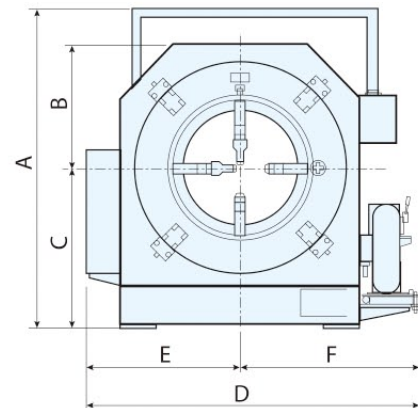

Unit (mm)

MODEL	PC550	PC840
Number of jaw	3	4
<b>A</b>	1980	2320
<b>B</b>	725	900
<b>C</b>	1000	1160
<b>D</b>	2080	2500
<b>E</b>	925	1160
<b>F</b>	1155	1340
<b>G</b>	880	1080
Gripping range <b>d1</b>	90~550	380~830
Gripping range <b>d2</b>	—	445~895
Gripping range in use of auxiliary jaw	—	60~360
Gripping force	15kN	19.5kN
Rotation speed	0.03~1.2min <sup>-1</sup>	0.05~3min <sup>-1</sup>
Jaw traveling speed	150mm/min	150mm/min

Manufacture of special products can be made.

# CENTER DRILL MACHINE

■ Light weight • Speedy • Easy operation

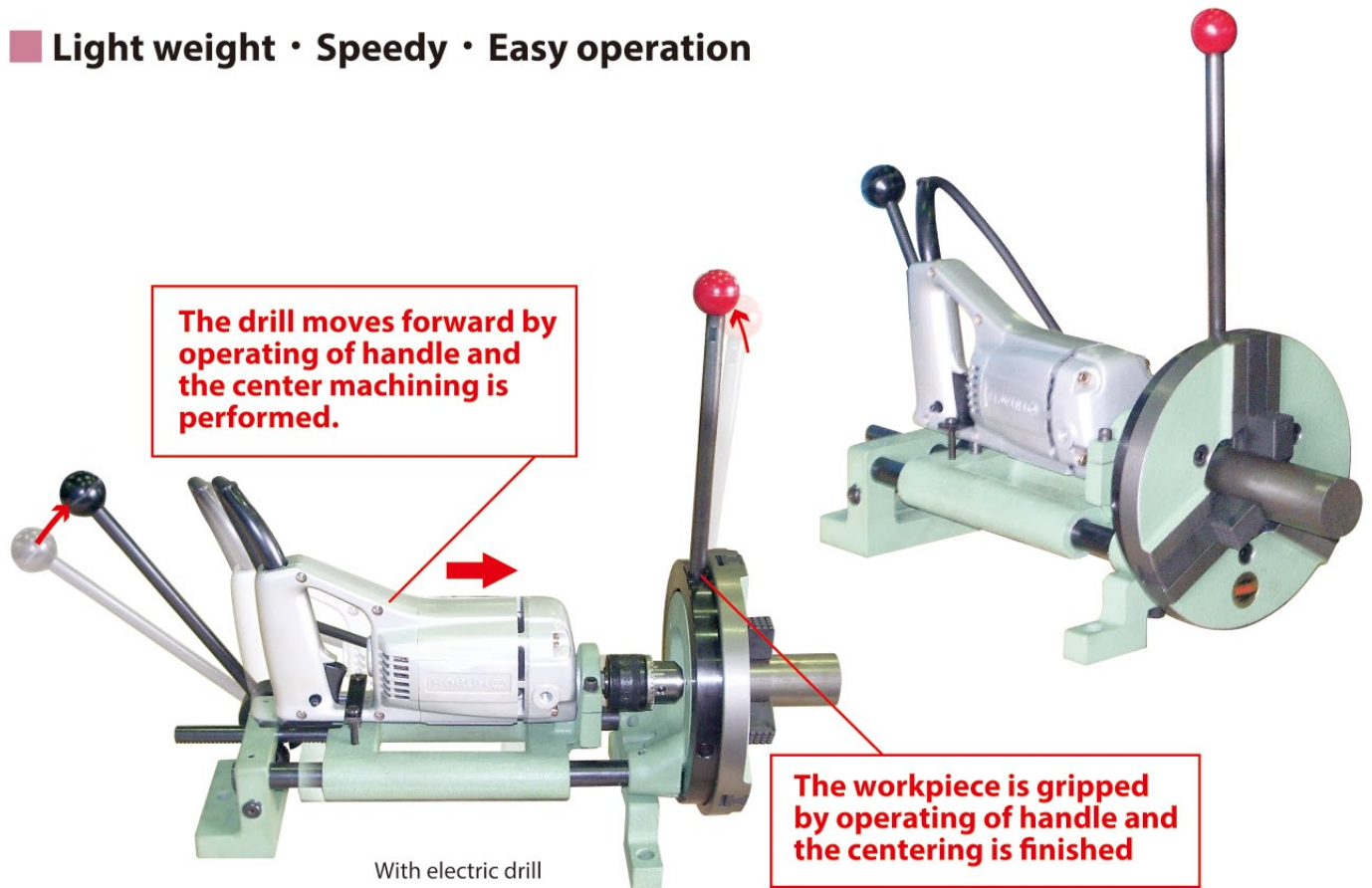

With electric drill

The workpiece is gripped by operating of handle and the centering is finished

Unit (mm)

MODEL	C-200	C-300
Code No.	720100	720200
L	433	442
H	250	342
B	200	300
Chuck diameter inside	82	100
Gripping range	φ15~φ200	φ50~φ300
Drill chuck	13	13
Max. speed	1100 r.p.m	1100 r.p.m
Power source	100 V (6.5A)	100 V (6.5A)
Length of cord	5 m	5 m
weight	15 kg	26 kg

■ Machining of large workpiece



SPECIAL CHUCK

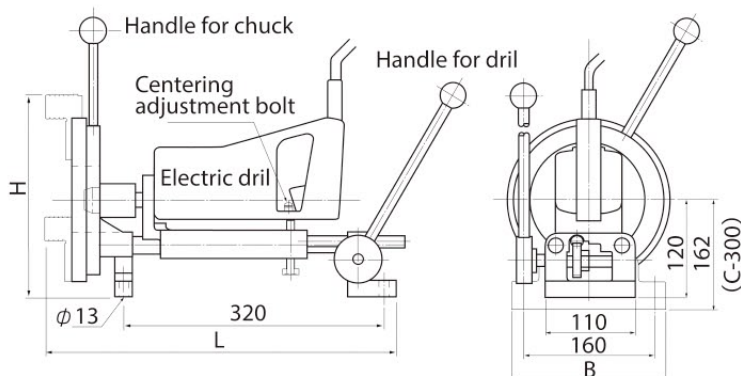

## TYPE VH FOR SMALL VALVES

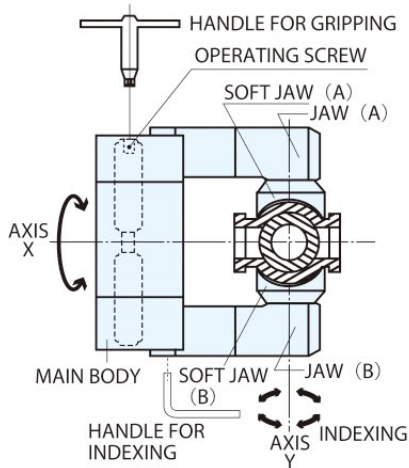
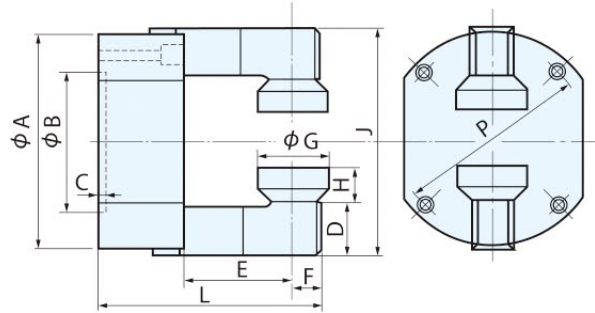
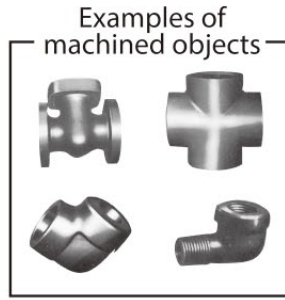
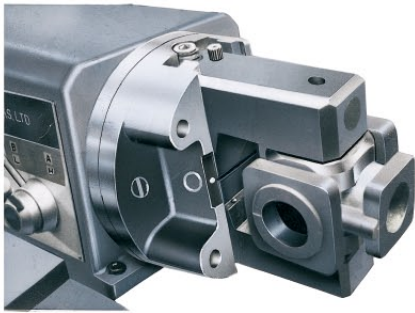

MODEL	No.	A	B	C	D	E	F	G	H	J (MAX)	Unit (mm)
VH 6	150640	170	110	5	62	55	30	80	30	210	
VH 10	151040	250	170	8	65	100	35	118	40	290	
VH 12	151240	320	200	8	78	125	50	158	70	370	

MODEL	L	P	Gripping Range	Mounting Bolt	Max. Speed min <sup>-1</sup> (r.p.m)	Weight (kg)
VH 6	165	130	40-10	M12 × 95	1500	20
VH 10	236	210	100-30	M12 × 110	1100	40
VH 12	290	250	120-50	M16 × 140	650	97

Standard indexing angle 45°  
Accessories : One set of T-handle wrench, mounting bolts, eye bolt, and soft jaws

## TYPE VL FOR LARGE VALVES

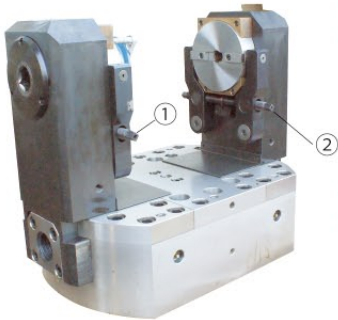

- Tighten a workpiece manually.
- To index, rotate the indexing handles ① and ② to unlock and rotate the spindle for indexing, and fix the spindle with the handles ① and ②.
- Indexing angle : 45°
- One-touch indexing is enabled while chucking a workpiece.

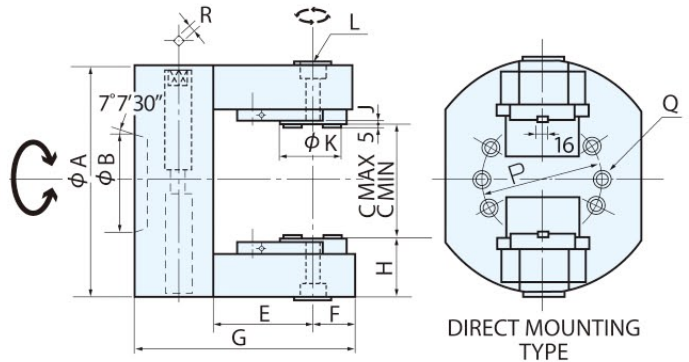

MODEL	VL12A8	VL15A8	VL18A11	VL21A11	VL24A15	VL28A15	Unit (mm)
No.	151253	151553	151854	152154	152455	152855	
A	320	381	460	533	610	710	
B	139.719	139.719	196.869	196.869	285.775	285.775	
C	MAX	163	210	260	320	360	460
	MIN	70	110	150	150	220	280
E	130	170	200	240	300	350	
F	50	58	80	80	110	110	
G	310	358	430	470	610	670	
H	86	98	118	118	156	156	
J	4	4	5	5	5	5	
K	90	90	130	130	210	210	
L	M 12	M 16	M 20	M 20	M 20	M 20	
P	171.4	171.4	235	235	330.2	330.2	
Q	6-M16 × 135	4-M16 × 140	6-M20 × 160	6-M20 × 160	6-M22 × 210	6-M22 × 220	
R	16	16	22	22	22	22	
Max. Speed min <sup>-1</sup> (r.p.m)	700	550	440	360	300	250	
Weight (kg)	120	150	210	300	420	630	

SPECIAL CHUCK

## TYPE VA FOR SMALL VALVES

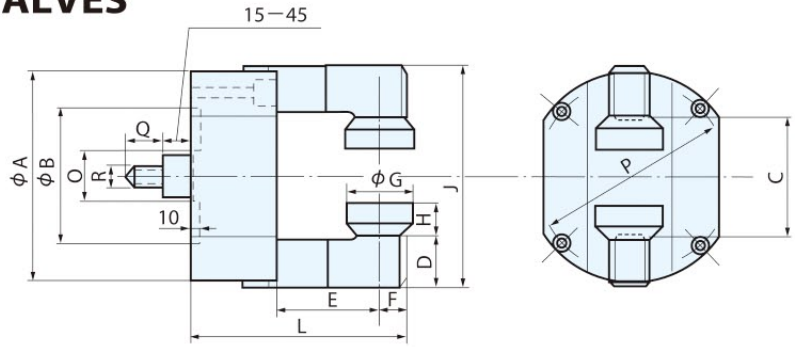
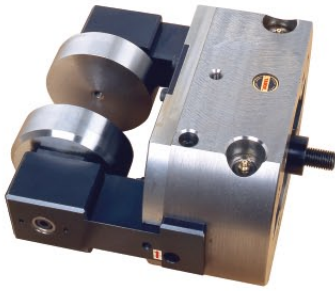

Unit (mm)

MODEL	No.	A	B	C	D	E	F	G	H	J(MAX)	L
VA 270	151143	270	120	119-149	63	100	35	118	40	290	248
VA 320	151243	320	180	136-166	78	125	50	158	70	360	310

MODEL	O	P	Q	R	Mounting Bolt	Jaw Stroke	Gripping Range	Plunger Stroke	Max. Speed min <sup>-1</sup> (r.p.m)	Weight (kg)
VA 270	80	150	30	M 20	M12×120	15	55-100	30	1000	50
VA 320	100	220	40	M 22	M16×160	15	60-120	30	650	105

Standard indexing angle 45°

Accessories : One set of T-handle wrench, mounting bolts, eye bolt, and soft jaws

## TYPE VX FOR LARGE VALVES

- Tighten a workpiece to the spindle from the rear side by a hydraulic cylinder
- Rotate the indexing handle in the same manner as the VL type for indexing
- Direct mounting type
- Indexing angle : 45°

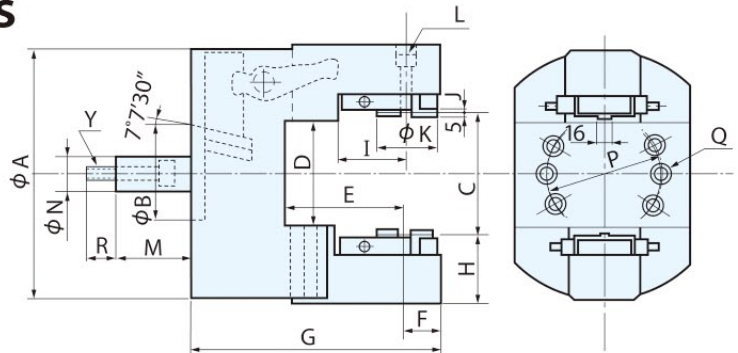

Unit (mm)

MODEL	VX12A8	VX15A8	VX18A11	VX21A11	VX24A15
No.	151233	151533	151834	152134	152435
A	320	381	460	533	610
B	139.719	139.719	196.869	196.869	285.775
C	MIN	128	165	180	242
	MAX	162	203	253	310
D	130	160	200	240	260
E	130	178	200	240	300
F	50	55	70	70	110
G	325	378	420	475	575
H	89	103	126	140	150
I	106	106	145	140	193
J	4	4	5	5	5
K	90	90	130	130	210
L	M 12	M 12	M 20	M 20	M 20
M	MIN	92	92	0	0
	MAX	122	125	40	50
N	52	52	65	75	75
P	171.4	171.4	235	235	330.2
Q	6-M16×150	6-M16×150	6-M20×160	6-M20×170	6-M22×180
R	46	46	55	60	60
Y	M 24	M 24	M 30	M 36	M 36
Allowable Cylinder Thrust Force kN (kgf)	39 (4000)	39 (4000)	44 (4500)	49 (5000)	54 (5500)
Plunger Stroke	30	33	40	50	50
Jaw Stroke	17	19	36	34	36
Max. Speed min <sup>-1</sup> (r.p.m)	900	650	500	400	330
Weight (kg)	110	140	200	340	480

# NOBEL SPECIAL CHUCKS

## DRAW-DOWN CHUCK TYPE HD

- No work float since work is drawn to the chuck end surface to be gripped
- Less work deformation generated because of its 6-jaw chuck
- Suitable for gear shaper machining

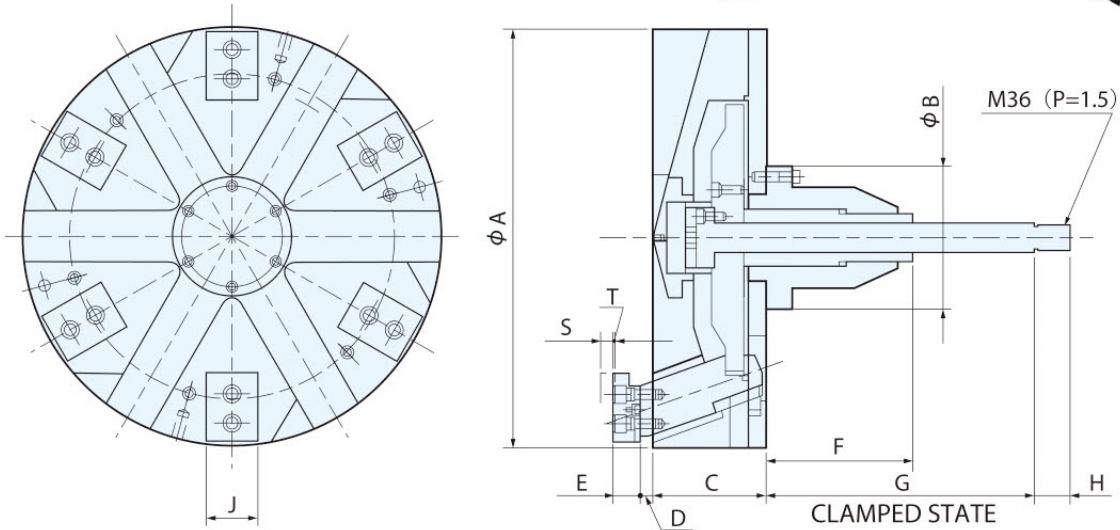
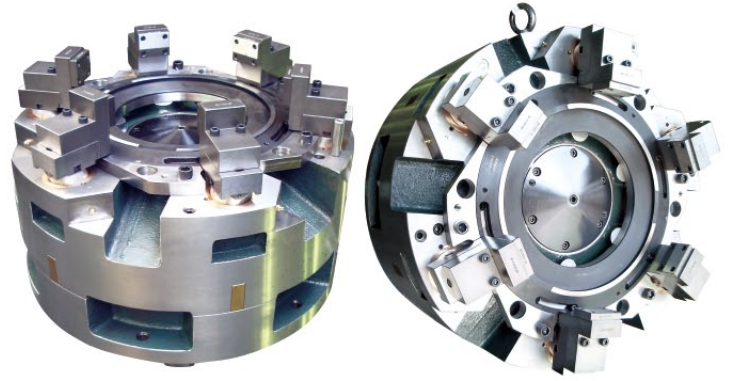

MODEL	A	B	C	D	E	F	G	H	J	S	T	Unit (mm)
<b>HD 580</b>	580	200	175	25	30	200	370	48	70	21	4	
<b>HD 700</b>	700	300	200	30	35	317	398					

MODEL	Jaw Stroke (mm)	Plunger Stroke (mm)	Allowable Plunger Force kN	Gripping Force kN	Weight (kg)
<b>HD 580</b>	9	25	20	38	400
<b>HD 700</b>			25	48	600

## HYDRAULIC CHUCK FOR CRANK SHAFT ( $\phi$ 2500, $\phi$ 2800)

- Driven by Hydraulic motor
- Jaws travel enables slow-speed and high-speed traveling
- Chuck weight 15t

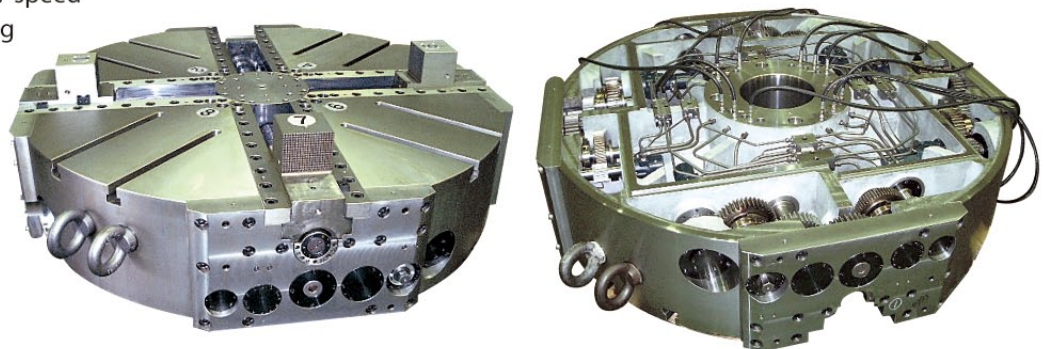

SPECIAL CHUCK

# SPECIAL WPS CHUCK WITH GRIPPED HANDLE

**TYPE GP**

● Used for glass or woodworking machines

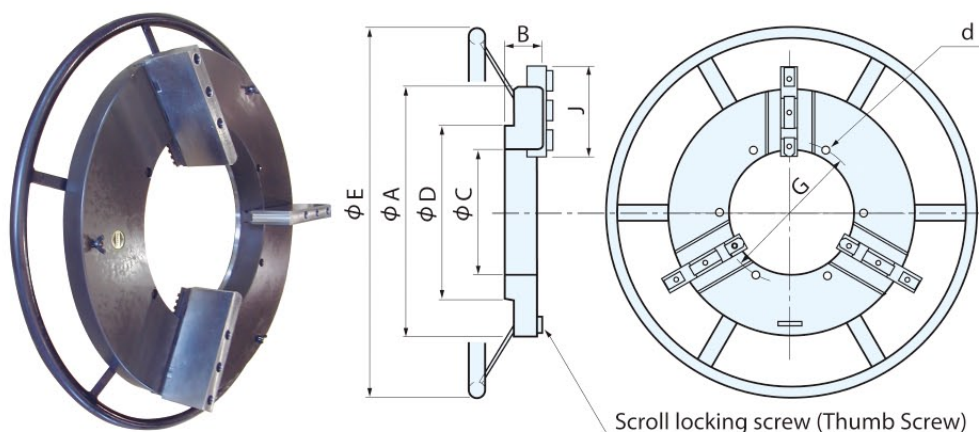

Scroll locking screw (Thumb Screw)

■ REFERENCE DIMENSION

MODEL	A	B	C	D	E	G	J	d	Unit (mm)
<b>GP 280 × 100</b>	280	43	100	150	400	120	120	6-M6	Jaw Stroke
<b>GP 400 × 200</b>	400	48	200	280	600	230	120	6-M8	50
<b>GP 520 × 300</b>	520	55	300	360	720	325	170	6-M8	80
<b>GP 565 × 350</b>	565	55	350	415	750	380	170	6-M8	80
<b>GP 750 × 400</b>	750	83	400	510	1070	430	240	9-M8	95

## SPECIAL CHUCKS

**POWER CHUCK FOR VERTICAL LATHE  $\phi$  1650**



**SPECIAL RETIGHTENING INDEPENDENT CHUCK  $\phi$  800~ $\phi$  1800**

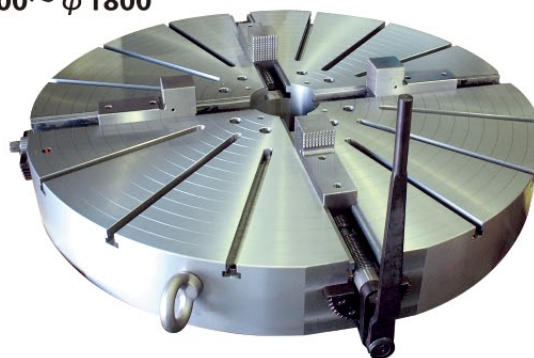

**SPECIAL POWER WRENCH CHUCK  $\phi$  400~ $\phi$  1800**

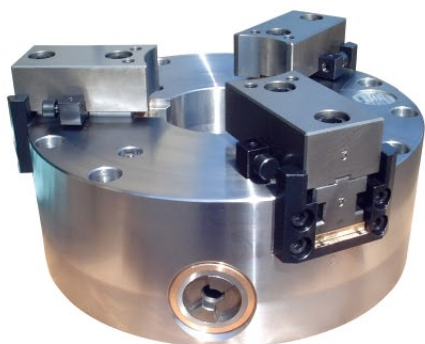

**CHUCK FOR VERTICAL GRINDING MACHINE**

- Watertight specification
- Fine adjustable jaws included



**CHUCK EQUIPED HYDRAULIC MOTOR**

- For use on MC

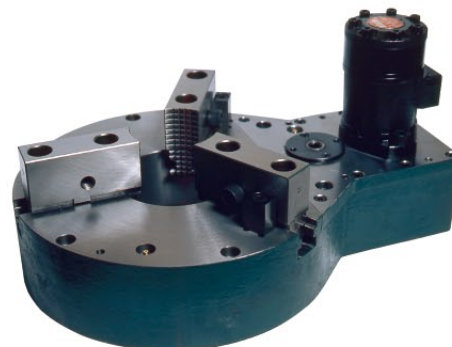

SPECIAL CHUCK

# NOBEL SPECIAL CHUCKS

## SPECIAL INDEXING CHUCK

- For machining couplings
- Enables 180° indexing



## φ 1600 SPECIAL CHUCK PALLET

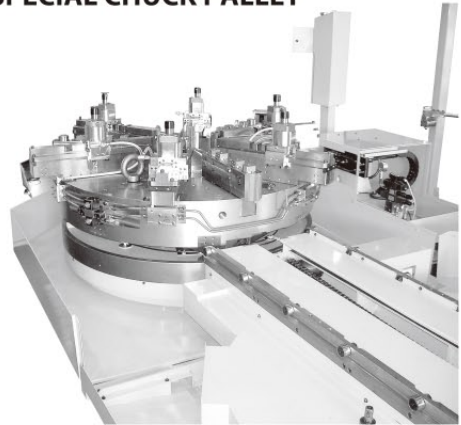

## φ 3500 SPECIAL CHUCK PALLET

- For machining large-sized rings

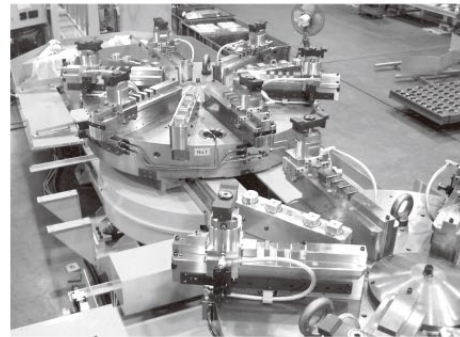

## CORE CYLINDER CHUCK JIG FOR LARGE-SIZED MOTOR

φ 920~1200 mm



## CHUCK WITH HYDRAULIC MOTOR φ 1350~φ 1600

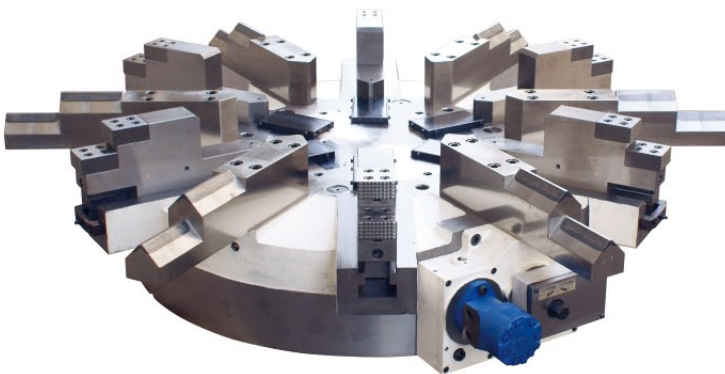



# NOBEL SPECIAL CHUCKS

φ 2600 CHUCK WITH FINE ADJUSTMENT FUNCTION

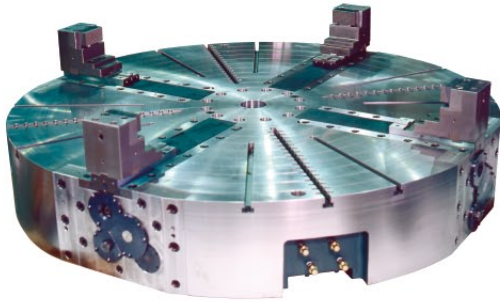

φ 1200 CHUCK WITH HYDRAULIC MOTOR



2 JAW FLOATINGCHUCK

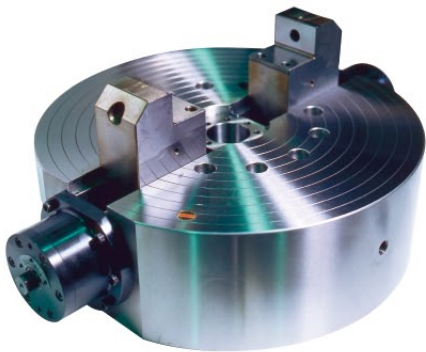

COUPLING CLAMP CHUCK  
FOR OIL WELL PIPE

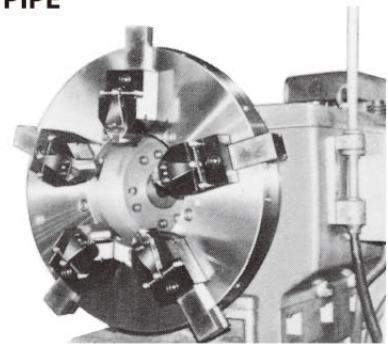

4 JAW FLOATINGCHUCK

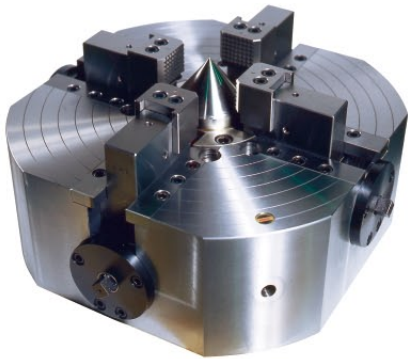

PALLET □400~□800

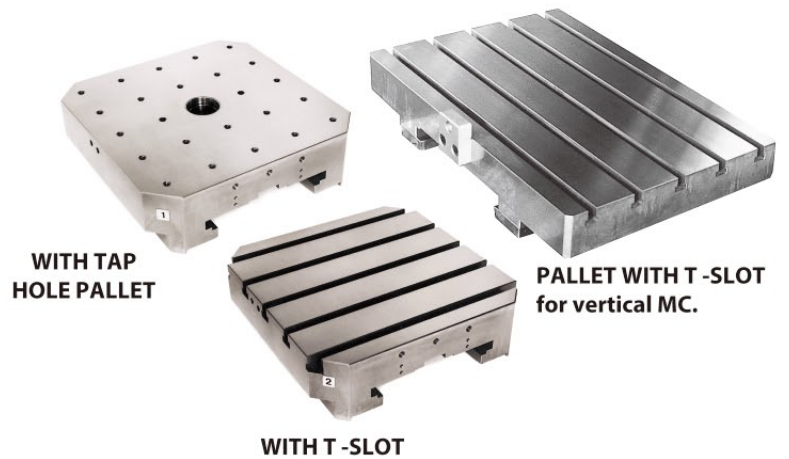

WITH TAP  
HOLE PALLET

PALLET WITH T -SLOT  
for vertical MC.

WITH T -SLOT

DUSTPROOF

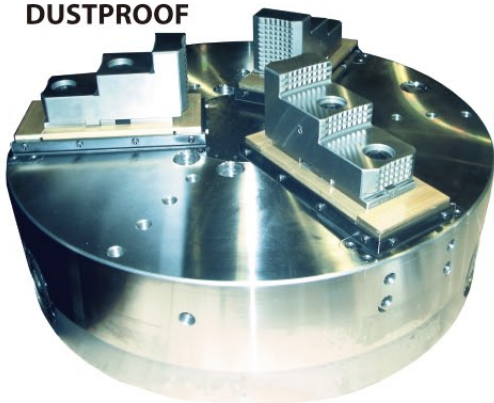

# MACHINING CENTER ACCESSORIES

For product information, please refer to the “TOUCHDEX and Machining center accessories” catalog.

## TOUCHDEX

The TOUCHDEX is mounted on the machining center table in the same manner as a CNC index table for fully automatic indexing of the workpiece.

In contrast to CNC index tables, the TOUCHDEX does not incorporate a servo motor, but uses the Z axis movement of the machining center to rotate the table for indexing.

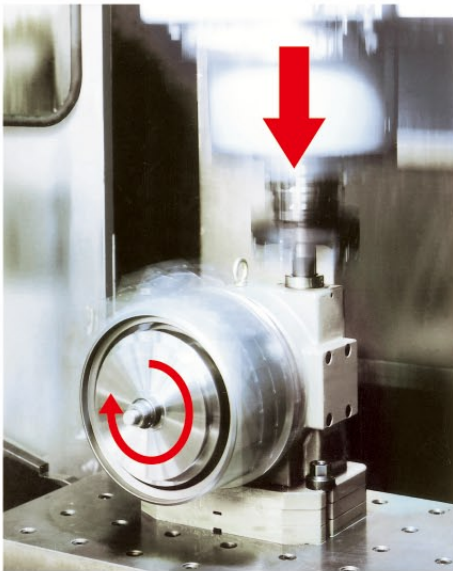

TILTING 230-150



Table size  $\phi 107 - \phi 450$

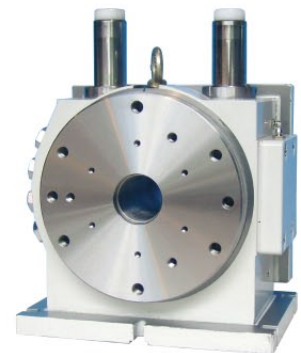

FDR type

## MACHINING CHUCK Y-TYPE

Suitable for use as a clamping Jig for machining centers

Size : 120, 160, 200, 300 (mm)

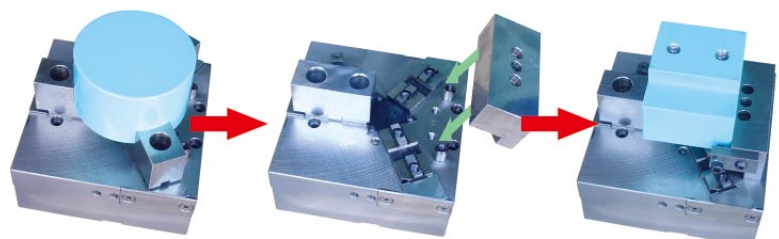
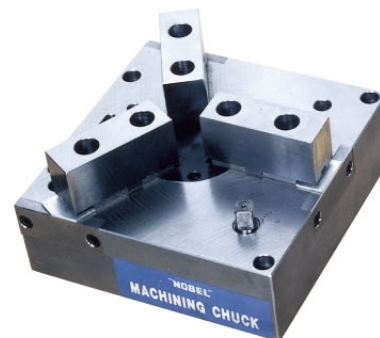
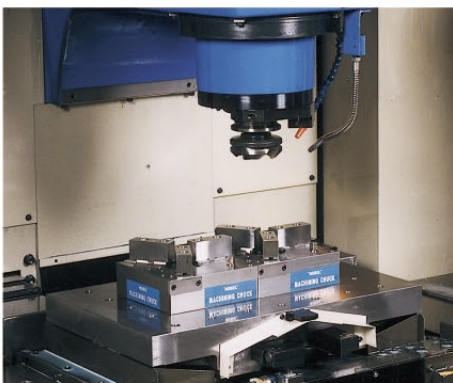

Secure a round workpiece by using 3 jaws

Install fixed jaw (optional accessory)

For use as VISE

# PALLET CHANGER & TOOL CHANGER

PALLET POOL



RACK MAGAZINE



PALLET CHANGER FOR VERTICAL LATHE

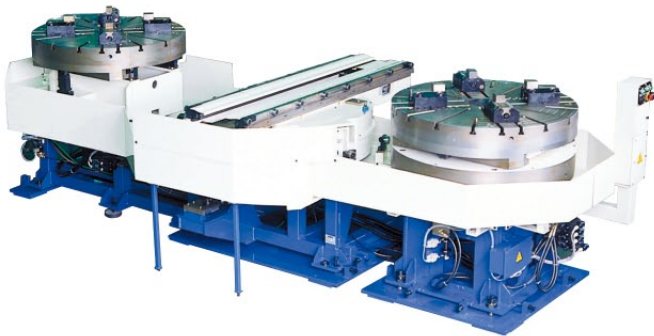

TOOL CHANGER



PALLET CHANGER

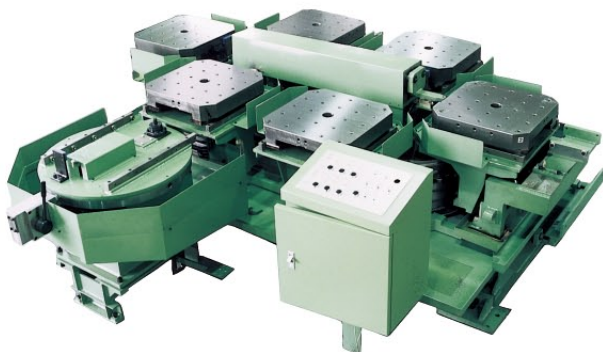

PALLET CHANGER FOR MACHINING CENTER



26082000

KAWATATEC



■ All specifications are subject to change without notice.

**KAWATATEC CORP.**

PHONE 0744-45-0360 FAX 0744-45-0364  
48-1, HASHIMOTO SAKURAI NARA,  
633-0047 JAPAN

U R L : <http://www.kawatatec.co.jp>  
E m a i l : [info@kawatatec.co.jp](mailto:info@kawatatec.co.jp)